

## DB

ceiling fixed bracket

ceiling fixed bracket, profile rail 30x15 mm

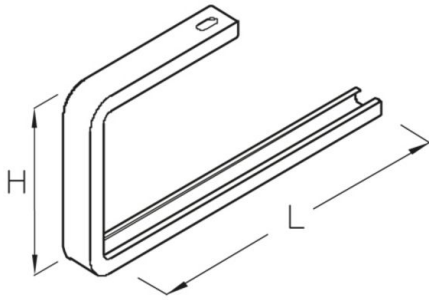

$F_D/P$ : coefficient for calculation of the dowel load  $F_D$  with effective bracket load  $P$  respectively the sum of effective bracket loads. This article is available made in material No. 1.4571/1.4404 (V4A) stainless steel finish.

### Continuously hot galvanized (Sendzimir process) (DIN EN 10346)

Product	H	B	L	$P_{max}$	$F_D/P$	G
DB 10S	170 mm	100 mm	110 mm	0,6 kN	1,2	0,25 kg
DB 20S	170 mm	200 mm	210 mm	0,4 kN	1,1	0,36 kg
DB 30S	170 mm	300 mm	310 mm	0,28 kN	1,1	0,47 kg

### Stainless steel, according to ASTM 304 / BS 304 S 3

Product	H	B	L	$P_{max}$	$F_D/P$	G
DB 10E	170 mm	100 mm	110 mm	0,5 kN	1,2	0,3 kg
DB 20E	170 mm	200 mm	210 mm	0,35 kN	1,1	0,44 kg
DB 30E	170 mm	300 mm	310 mm	0,25 kN	1,1	0,58 kg

**H:** height

**B:** width

**L:** length

**$P_{max}$ :** Maximum load

**$F_D/P$ :** dowel-to-anchor load

**G:** weight

## DETAILS / APPLICATIONS



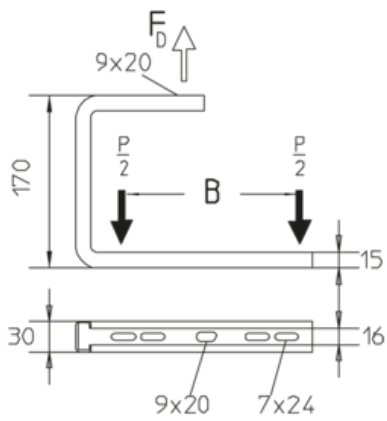

## OPTIONAL ACCESSORIES

KLR, SAZ

