

KAD-BS

bracket adapter Maintenance of function - Standard support structures

The product can be used for fire protection. For technical parameters, see National Technical Test Certificates (abPs).

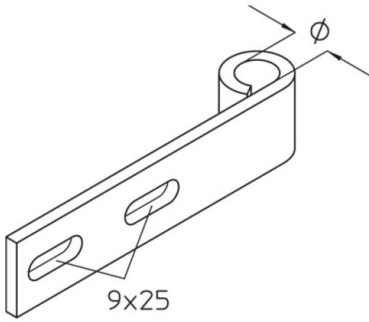

Continuously hot galvanized (Sendzimir process) (DIN EN 10346)

Product	Ø	G
KAD-BS S	13 mm	0,22 kg
incl.:		
2x IK 8X20	hexagon socket head screw, DIN 912	
2x SEMS 8	hexagon-nut with flange, DIN EN 1661	

Hot-dip galvanized, according to BS 729 (DIN EN ISO 1461)

Product	Ø	G
KAD-BS F	13 mm	0,23 kg
incl.:		
2x IK 8X20E	hexagon socket head screw, DIN 912	
2x SEMS 8E	hexagon-nut with flange, DIN EN 1661	

Ø: diameter

G: weight

OPTIONAL ACCESSORIES

SD, SAZ, GB, VM

