

KLTL

Beam clamp fixing cable ladder

The KLTL girder clamp is used to clamp cable ladders to horizontally crossing steel girders. Offset placement of the clamp prevents movement in the longitudinal direction. Two notch positions on the clamping leg allow the leg to be adapted to shorter girder flanges. For beam flange thickness 5 - 22 mm.

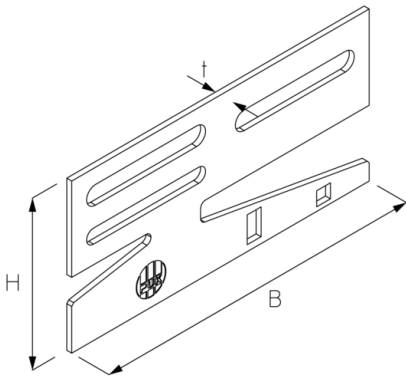

Continuously hot galvanized (Sendzimir process) (DIN EN 10346)

Product	H	B	t	G
KLTL S	75 mm	150 mm	2,5 mm	0,19 kg
incl.:				
1x SEMS 8	hexagon-nut with flange, DIN EN 1661			
1x FRSV 8X16	round-head screw with short square, DIN 603			

Hot-dip galvanized, according to BS 729 (DIN EN ISO 1461)

Product	H	B	t	G
KLTL F	75 mm	150 mm	2,5 mm	0,20 kg
incl.:				
1x SEMS 8E	hexagon-nut with flange, DIN EN 1661			
1x FRSV 8X16E	round-head screw with short square, DIN 603			

Stainless steel, according to ASTM 304 / BS 304 S 3

Product	H	B	t	G
KLTL E	75 mm	150 mm	2,5 mm	0,19 kg
incl.:				
1x SEMS 8E	hexagon-nut with flange, DIN EN 1661			
1x FRSV 8X16E	round-head screw with short square, DIN 603			



H: height
B: width
t: material thickness
G: weight

DETAILS / APPLICATIONS

