

## KLTR

### Beam clamp fixing cable tray

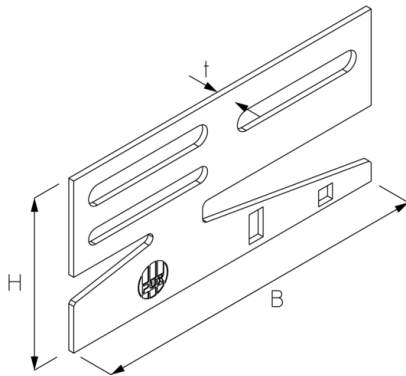

The KLTR girder clamp is used to clamp cable trays to horizontally crossing steel girders. Offset placement of the clamp prevents movement in the longitudinal direction. Two notch points on the clamping leg allow the leg to be adapted to shorter girder flanges. For beam flange thickness 5 - 22 mm. Compatible from R(G) 60.

#### Continuously hot galvanized (Sendzimir process) (DIN EN 10346)

Product	H	B	t	G
KLTR S	75 mm	150 mm	2,5 mm	0,17 kg
incl.:				
1x SEMS 6	hexagon-nut with flange, DIN EN 1661			
1x FRSV 6X12	round-head screw with short square, DIN 603			

#### Hot-dip galvanized, according to BS 729 (DIN EN ISO 1461)

Product	H	B	t	G
KLTR F	75 mm	150 mm	2,5 mm	0,18 kg
incl.:				
1x SEMS 6E	hexagon-nut with flange, DIN EN 1661			
1x FRSV 6X12E	round-head screw with short square, DIN 603			

#### Stainless steel, according to ASTM 304 / BS 304 S 3

Product	H	B	t	G
KLTR E	75 mm	150 mm	2,5 mm	0,17 kg
incl.:				
1x SEMS 6E	hexagon-nut with flange, DIN EN 1661			
1x FRSV 6X12E	round-head screw with short square, DIN 603			



**H:** height  
**B:** width  
**t:** material thickness  
**G:** weight

## DETAILS / APPLICATIONS

