

KWF

wall/handle bracket, light-duty

Wall/handle bracket, light-duty version made of folded sheet steel. Certified according to DIN EN 61537. For mounting on walls or hanging struts.

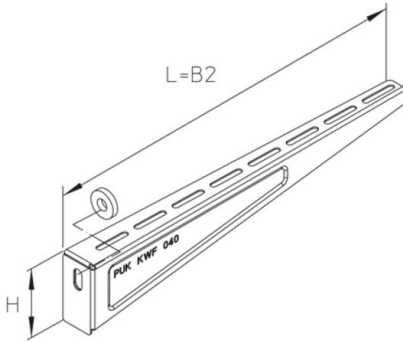

F_D/P : coefficient for calculation of the dowel load F_D with effective bracket load P respectively the sum of effective bracket loads. The load specifications are only valid with sufficient anchoring to the load-bearing substrate or with proper installation on hanging struts.

Continuously hot galvanized (Sendzimir process) (DIN EN 10346)

Product	H	B1	B2	L	P_{max}	F_D/P	G
KWF 010S	80 mm	100 mm	120 mm	120 mm	1,2 kN	1,58	0,21 kg
incl.:							
KWF 020S	80 mm	200 mm	220 mm	220 mm	1,2 kN	2,33	0,29 kg
incl.:							
KWF 030S	80 mm	300 mm	320 mm	320 mm	1,2 kN	3,15	0,43 kg
incl.:							
KWF 040S	80 mm	400 mm	420 mm	420 mm	1,2 kN	3,99	0,50 kg
incl.:							

Hot-dip galvanized, according to BS 729 (DIN EN ISO 1461)

Product	H	B1	B2	L	P_{max}	F_D/P	G
KWF 010F	80 mm	100 mm	120 mm	120 mm	1,2 kN	1,58	0,24 kg
incl.:							
KWF 020F	80 mm	200 mm	220 mm	220 mm	1,2 kN	2,33	0,32 kg
incl.:							
KWF 030F	80 mm	300 mm	320 mm	320 mm	1,2 kN	3,15	0,47 kg
incl.:							
KWF 040F	80 mm	400 mm	420 mm	420 mm	1,2 kN	3,99	0,54 kg
incl.:							



H: height
B1: width
B2: width
L: length
P_{max}: Maximum load
F_d/P: dowel-to-anchor load
G: weight

DETAILS / APPLICATIONS

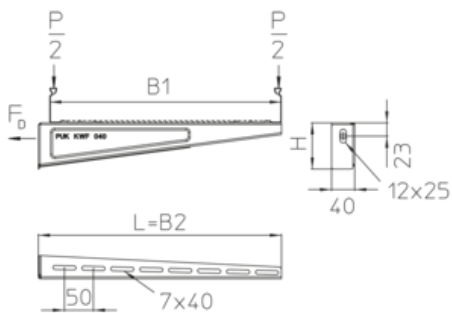

OPTIONAL ACCESSORIES

KDU 57, KHU 57, KDU 40, KHU 40

