

KWMS

wall/handle bracket, medium duty Maintenance of function, specified system

Wall/handle bracket, medium-heavy version, with welded-on back plate. Certified according to DIN EN 61537. For mounting on walls or hanging struts.

F_D/P : coefficient for calculation of the dowel load F_D with effective bracket load P respectively the sum of effective bracket loads. The load specifications are only valid with sufficient anchoring to the load-bearing substrate or with proper installation on hanging struts. The products can be used for fire protection. For technical parameters, see National Technical Test Certificates (abPs).

Hot-dip galvanized, according to BS 729 (DIN EN ISO 1461)

Product	H	B1	B2	L	P_{max}	F_D/P	G
KWMS 010F	110 mm	100 mm	115 mm	128 mm	3,8 kN	1,36	0,53 kg
KWMS 020F	110 mm	200 mm	215 mm	228 mm	3,8 kN	1,81	0,76 kg
KWMS 030F	110 mm	300 mm	315 mm	328 mm	3,8 kN	2,32	0,99 kg
KWMS 040F	110 mm	400 mm	415 mm	428 mm	3,8 kN	2,86	1,21 kg

H: height

B1: width

B2: width

L: length

P_{max} : Maximum load

F_D/P : dowel-to-anchor load

G: weight

DETAILS / APPLICATIONS



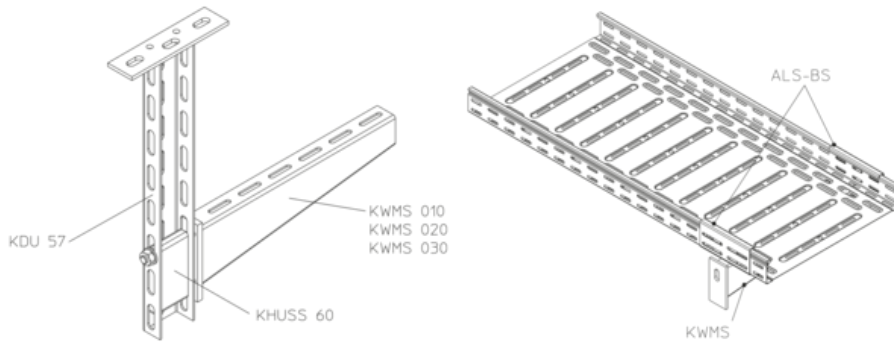

OPTIONAL ACCESSORIES

KLR, ALS-BS, SD, SAZ

