

MKD beam clamp

Steel mounting clamp with riveted pressure plate for clamp fastening to steel beams.

This article is also available with lock nuts. This prevents unintentional loosening of the clamping.

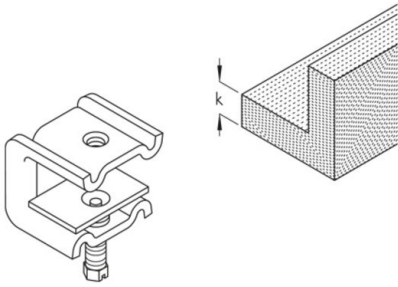

Hot-dip galvanized, according to BS 729 (DIN EN ISO 1461)

Product	B	Ø	k	P	M	G
MKD 21	44 mm	M8 mm	6-21 mm	1,5 kN	4 Nm	19 kg/100
MKD 21 M6	44 mm	M6 mm	6-21 mm	1,5 kN	4 Nm	18 kg/100
MKD 21 M10	44 mm	M10 mm	6-21 mm	1,5 kN	4 Nm	17,3 kg/100
MKD 40	44 mm	M8 mm	20-40 mm	1,3 kN	4 Nm	20,4 kg/100

Stainless steel, according to ASTM 304 / BS 304 S 3

Product	B	Ø	k	P	M	G
MKD 21E	44 mm	M8 mm	6-21 mm	1,5 kN	4 Nm	19 kg/100
MKD 40E	44 mm	M8 mm	20-40 mm	1,3 kN	4 Nm	19,3 kg/100

Stainless steel, according to ASTM 31 Ti / AISI 316 L, BS 320S17 / BS 316S11

Product	B	Ø	k	P	M	G
MKD 21E4	44 mm	M8 mm	6-21 mm	1,5 kN	4 Nm	19 kg/100
MKD 40E4	44 mm	M8 mm	20-40 mm	1,3 kN	4 Nm	19,3 kg/100





Hot-dip galvanized, according to BS 729 (DIN EN ISO 1461)

Product	B	Ø	k	P	M	G
MKD 21-HDG	44 mm	M8 mm	6-21 mm	1,5 kN	4 Nm	19 kg/100
MKD 21 M6-HDG	44 mm	M6 mm	6-21 mm	1,5 kN	4 Nm	18 kg/100
MKD 21 M10-HDG	44 mm	M10 mm	6-21 mm	1,5 kN	4 Nm	17,3 kg/100

Stainless steel, according to ASTM 304 / BS 304 S 3

Product	B	Ø	k	P	M	G
MKD 21-304	44 mm	M8 mm	6-21 mm	1,5 kN	4 Nm	19 kg/100

Stainless steel, according to ASTM 31 Ti / AISI 316 L, BS 320S17 / BS 316S11

Product	B	Ø	k	P	M	G
MKD 21-316	44 mm	M8 mm	6-21 mm	1,5 kN	4 Nm	19 kg/100

Hot-dip galvanized, according to BS 729 (DIN EN ISO 1461)

Product	B	Ø	k	P	M	G
MKD 40-HDG	44 mm	M8 mm	20-40 mm	1,3 kN	4 Nm	20,4 kg/100

Stainless steel, according to ASTM 304 / BS 304 S 3

Product	B	Ø	k	P	M	G
MKD 40-304	44 mm	M8 mm	20-40 mm	1,3 kN	4 Nm	19,3 kg/100

Stainless steel, according to ASTM 31 Ti / AISI 316 L, BS 320S17 / BS 316S11



Product	B	Ø	k	P	M	G
MKD 40-316	44 mm	M8 mm	20-40 mm	1,3 kN	4 Nm	19,3 kg/100

B: width
Ø: diameter
k: clamping range
P: loading
M: torque
G: weight

DETAILS / APPLICATIONS

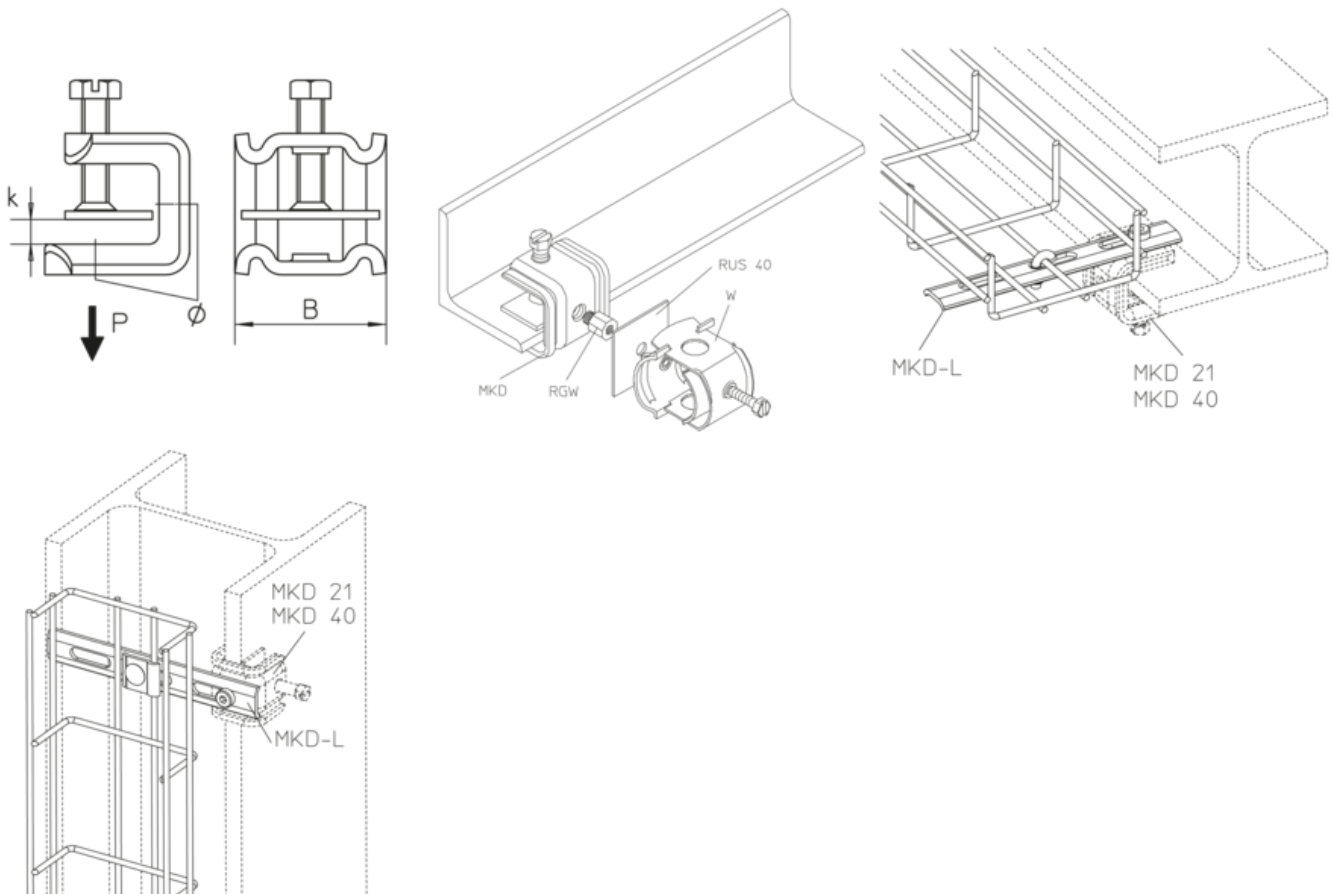

OPTIONAL ACCESSORIES

MKD L



