

RS 60

cable tray, unperforated, heavy, height = 60 mm

heavy cable tray, not perforated, head shape suitable for positive locking covers, certified including electrical conductivity according to DIN EN 61537/VDE 0639

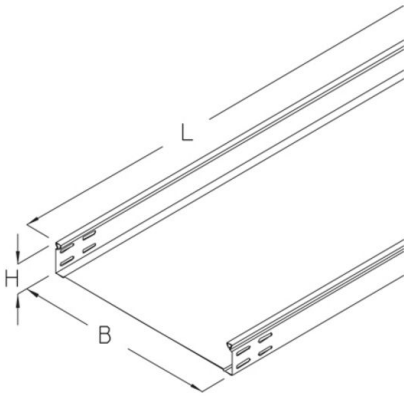

Continuously hot galvanized (Sendzimir process) (DIN EN 10346)

Product	H	B	L	t	A	Q _{SK}	G
RS 60-10S	60 mm	100 mm	3000 mm	1,50 mm	57 cm ²	0,09 kN/m	9,00 kg
RS 60-20S	60 mm	200 mm	3000 mm	1,50 mm	117 cm ²	0,18 kN/m	12,60 kg
RS 60-30S	60 mm	300 mm	3000 mm	1,50 mm	177 cm ²	0,27 kN/m	16,10 kg
RS 60-40S	60 mm	400 mm	3000 mm	1,50 mm	237 cm ²	0,36 kN/m	19,60 kg
RS 60-50S	60 mm	500 mm	3000 mm	1,50 mm	297 cm ²	0,45 kN/m	23,20 kg
RS 60-60S	60 mm	600 mm	3000 mm	1,50 mm	357 cm ²	0,54 kN/m	26,70 kg

Hot-dip galvanized, according to BS 729 (DIN EN ISO 1461)

Product	H	B	L	t	A	Q _{SK}	G
RS 60-10F	60 mm	100 mm	3000 mm	1,50 mm	57 cm ²	0,09 kN/m	9,60 kg
RS 60-20F	60 mm	200 mm	3000 mm	1,50 mm	117 cm ²	0,18 kN/m	13,30 kg
RS 60-30F	60 mm	300 mm	3000 mm	1,50 mm	177 cm ²	0,27 kN/m	17,10 kg
RS 60-40F	60 mm	400 mm	3000 mm	1,50 mm	237 cm ²	0,36 kN/m	20,80 kg
RS 60-50F	60 mm	500 mm	3000 mm	1,50 mm	297 cm ²	0,45 kN/m	24,60 kg
RS 60-60F	60 mm	600 mm	3000 mm	1,50 mm	357 cm ²	0,54 kN/m	28,30 kg

H: height
B: width
L: length



t: material thickness
A: cross section area
Q_{SK}: distributed load control cable
G: weight

DETAILS / APPLICATIONS

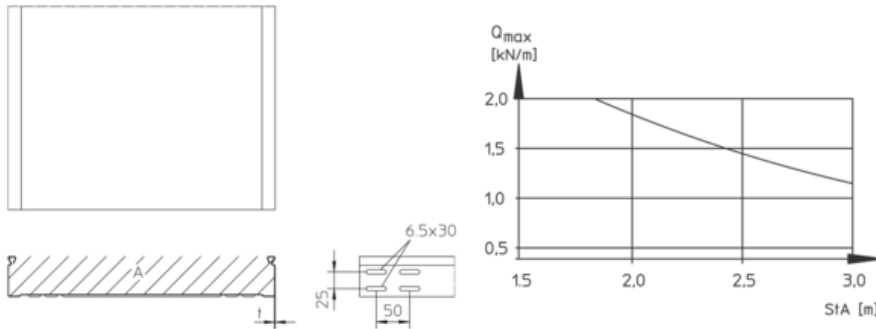

OPTIONAL ACCESSORIES

RB 60, RB45 60, RBV 60, RAE 60, RAA 60, RA 60, RK 60, RVB 60, RR 60, RAB 60, REB, RGV 60, VB, RTR 60, KLR, RD, RDR, RDS, RDSR



Do not walk upon!

