

WPF-P 60

flange mounting clamp (profiles)

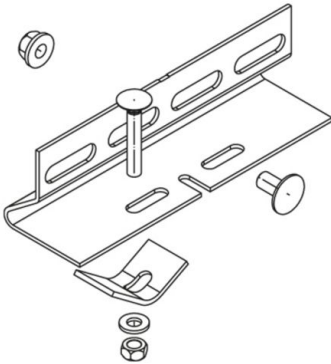

Hot-dip galvanized, according to BS 729 (DIN EN ISO 1461)

Product	G
WPF06-P-HDG	0,59 kg
incl.:	
1x KLS 8X16-304	clamp fastening set
1x SEM 8-304	hexagon-nut, DIN 934

G: weight

DETAILS / APPLICATIONS

