



Fastenings

Clamping assembly	H03-H11
Plugs	H12-H15
Suspension components	H16-H32
Bolting fasteners/ bolts and nuts	H33-H42
Channel nuts and bolts	H43-H47
Electrical fastenings	H48-H51

Numeric index

Fastenings

A

AKB channel bolt, A7/ A8/ A9 [G47](#)
AM12 channel nut, B3/ B6 [G46](#)
AM16 channel nut, B7 [G45](#)
AM18 channel nut, A7/ A8 [G44](#)
AM22 channel nut, A41/ KHA 41/ KHAL 41 [G43](#)
AMA18 channel nut, A7/ A8 [G44](#)
AMF18 channel spring nut, A7/ A8 [G45](#)
AMF22 channel spring nut, A41 [G43](#)
AN support [G11](#)

B

BFS K quick-mounting clip for all-rounder cable holder, plastic [G50](#)
BFS ND K quick-mounting clip for all-rounder cable holder, plastic with nail plug [G50](#)

D

DAS wire eyebolt [G17](#)

F

FKS slotted cylinder head screw, DIN 84 [G35](#)
FR spring ring [G39](#)
FRS round-head screw with square, DIN 603 [G35](#)
FRSV round-head screw with short square [G34](#)
FS serrated lock washer [G39](#)

G

GB threaded rod, DIN 976-1 [G16](#)
GCB beam clip [G31](#)
GRIPADAP thread adaptor with hole [G30](#)
GRIPCLE 1 adjustment key [G32](#)
GRIPCLE 2 adjustment key [G32](#)
GRIPM pigtail anchor bolt [G31](#)
GRIPPINC wire cutter [G32](#)
GRIPTRAP trapezium lock [G30](#)
GRIPTRAPP trapezium lock plus [G31](#)
GRIPTWIS wire end cap [G32](#)

H

HFE C 3 wire suspension with hook and universal closure [G18](#)
HFECEXP 1 wire suspension with hook and express closure [G18](#)
HFECEXP 2 wire suspension with hook and express closure [G18](#)
HFEF10 3 wire suspension with threaded end M10 and universal closure [G21](#)
HFEF10 4 wire suspension with threaded end M10 and universal closure [G21](#)
HFEF10EXP 2 wire suspension with threaded end M10 and express closure [G20](#)
HFEF6 2 wire suspension with threaded end M6 and universal closure [G19](#)
HFEF6 3 wire suspension with threaded end M6 and universal closure [G19](#)
HFEF6EXP 1 wire suspension with threaded end M6 and express closure [G19](#)
HFEF6EXP 2 wire suspension with threaded end M6 and express closure [G19](#)
HFEF8 2 wire suspension with threaded end M8 and universal closure [G20](#)
HFEF8 3 wire suspension with threaded end M8 and universal closure [G20](#)
HFEF8EXP 2 wire suspension with threaded end M8 and express closure [G20](#)
HFEM 2 wire suspension with carbine and universal closure [G21](#)
HFEM 3 wire suspension with carbine and universal closure [G21](#)
HFEO 3 wire suspension with eyelet straight and universal closure [G22](#)

HFEOEXP 2 wire suspension with eyelet straight and express closure [G22](#)
HFET6EXP 1 wire suspension with threaded transition M6 and express closure [G22](#)
HFET6EXP 2 wire suspension with threaded transition M6 and express closure [G22](#)
HFET8EXP 2 wire suspension with threaded transition M8 and express closure [G23](#)
HFFR 2 wire suspension with loop and universal closure [G23](#)
HFFR 3 wire suspension with loop and universal closure [G24](#)
HFFR 4 wire suspension with loop and universal closure [G24](#)
HFFR 5 wire suspension with loop and universal closure [G24](#)
HFFREXP 1 wire suspension with loop and express closure [G23](#)
HFFREXP 2 wire suspension with loop and express closure [G23](#)
HFSP 2 wire suspension with cross anchor and universal closure [G25](#)
HFSP 3 wire suspension with cross anchor and universal closure [G25](#)
HFSPEXP 1 wire suspension with cross anchor and express closure [G24](#)
HFSPEXP 2 wire suspension with cross anchor and express closure [G25](#)
HFTHEXP 1 wire suspension with trapezium sheet metal hook and express closure [G25](#)
HFTHEXP 2 wire suspension with trapezium sheet metal hook and express closure [G26](#)
HS12 Tee-head bolt [G46](#)
HS16 Tee-head bolt [G46](#)
HS18 tee-head bolt, A7/ A8/ A9 [G45](#)
HS22 tee-head bolt, A2/ A4 [G43](#)

I

IK hexagon socket head screw, DIN 912 [G36](#)

K

KD plastic dowel [G13](#)
KLR fixing set [G33](#)
KLRL clamping assembly [G36](#)
KLS fixing set [G33](#)
KLU fixing set [G07](#)
KLUS clamping assembly [G08](#)
KLUT clamping assembly [G09](#)
KNK chain [G17](#)
KNK-NG chain, emergency link [G17](#)
KOT K coupling piece, plastic [G50](#)
KSD plastic plug-in dowel [G51](#)

L

LK K cable holder, plastic [G49](#)
LK ND K cable holder, plastic with moulded-in nail plug [G50](#)

M

MKD beam clamp [G09](#)

R

RGW reducing bolt [G11](#)
RUS 41 stabilization plate, KHA profiles [G41](#)
RUS 50 mounting plate, KHA profiles [G42](#)

S

SA anchor [G13](#)
SA-D anchor [G13](#)
SAZ anchor [G12](#)
SAZ-B Ferro-concrete drill [G12](#)
SAZ-D anchor [G13](#)
SD expansion anchor [G12](#)
SD-BS straddling dowel, fire protection [G51](#)
SEH hexagon wood screw [G38](#)

SEM hexagon-nut, DIN 934 [G41](#)
SEMS hexagon nut, self-locking, DIN 6923 [G41](#)
SEMSS hexagon-nut, self-locking, DIN 985 [G42](#)
SES hexagon head bolt, DIN 933 [G37](#)
SH K multiple cable holder, plastic [G48](#)
SH ND K multiple cable holder, plastic with nail plug [G48](#)
SH QS multiple cable holder, metal [G48](#)
SHH eyebolt [G18](#)
SHK K cable holder, plastic [G49](#)
SHK ND K cable holder, plastic with nail plug [G49](#)
SHS eyebolt [G17](#)
SK clamping claw [G10](#)
SKL A beam clamp set [G07](#)
SKL M beam clamp set [G06](#)
SKS A beam clamp set [G04](#)
SKS H beam clamp set [G03](#)
SKS M beam clamp set [G05](#)
SN screw nail anchor [G51](#)
SN G beam clamp [G10](#)
SPRINGCLIP spring clip [G31](#)
SSK protection end cap [G42](#)

T

TBS trapezium bow [G16](#)
TIGERCLIP Tiger clip [G31](#)
TPZPEC 2 wire suspension with hook and trapezium closure plus [G26](#)
TPZPEC 3 wire suspension with hook and trapezium closure plus [G26](#)
TPZPEF10 2 wire suspension with threaded end M10 and trapezium closure plus [G27](#)
TPZPEF10 3 wire suspension with threaded end M10 and trapezium closure plus [G27](#)
TPZPEF10 4 wire suspension with threaded end M10 and trapezium closure plus [G27](#)
TPZPEF8 2 wire suspension with threaded end M8 and trapezium closure plus [G26](#)
TPZPEF8 3 wire suspension with threaded end M8 and trapezium closure plus [G27](#)
TPZPFR 2 wire suspension with loop and trapezium closure plus [G28](#)
TPZPFR 3 wire suspension with loop and trapezium closure plus [G28](#)
TPZPFR 4 wire suspension with loop and trapezium closure plus [G28](#)
TPZPSP 2 wire suspension with cross anchor and trapezium closure plus [G28](#)
TPZPSP 3 wire suspension with cross anchor and trapezium closure plus [G29](#)
TPZPTH 2 wire suspension with trapezium sheet metal hook and trapezium closure plus [G29](#)

U

US 125 square washer, DIN 125 [G39](#)
US 9021 square washer, DIN 9021 [G40](#)
UVS captive washer [G40](#)

V

VA-AP shear connector rod, pistol [G14](#)
VAB-HB shear connector rod, concrete [G14](#)
VAB-HB B shear connector rod, brush [G14](#)
VAB-HB M shear connector mortar [G14](#)
VAS-AS shear connector rod, stone [G15](#)
VAS-BS shear connector rod, fire protection [G15](#)
VAS-M shear connector mortar [G15](#)
VAS-SH perforated bush for shear connector, stone [G15](#)
VM rod coupling [G16](#)

Y

YAJCT 2 Y-Fit accessory with hook for cable trays [G30](#)
YAJEC 1 Y-Fit accessory with hook [G29](#)
YAJEC 2 Y-Fit accessory with hook [G29](#)
YAJEC 3 Y-Fit accessory with hook [G30](#)

Fastenings

Clamping assembly

SKS H beam clamp set

For an application example, see the chapter assembly.

article number	k mm	P _{max} kN	M Nm	G kg/set
F				
SKS HF	10 - 30	20	50	0,61

accessories included:

2 x **HS22 10x80F** tee-head bolt, A2/ A4 (page G44)
 2 x **US 10x30F** square washer, DIN 9021 (page G40)

article number	k mm	P _{max} kN	M Nm	G kg/set
E4				
SKS HE4	10 - 30	20	50	0,63

accessories included:

2 x **HS22 10x80E4** tee-head bolt, A2/ A4 (page G44)
 2 x **US 10x30E4** square washer, DIN 9021 (page G40)

accessories optional:

KHA 2 C-rail, perforated, 50x31 mm (page F57)

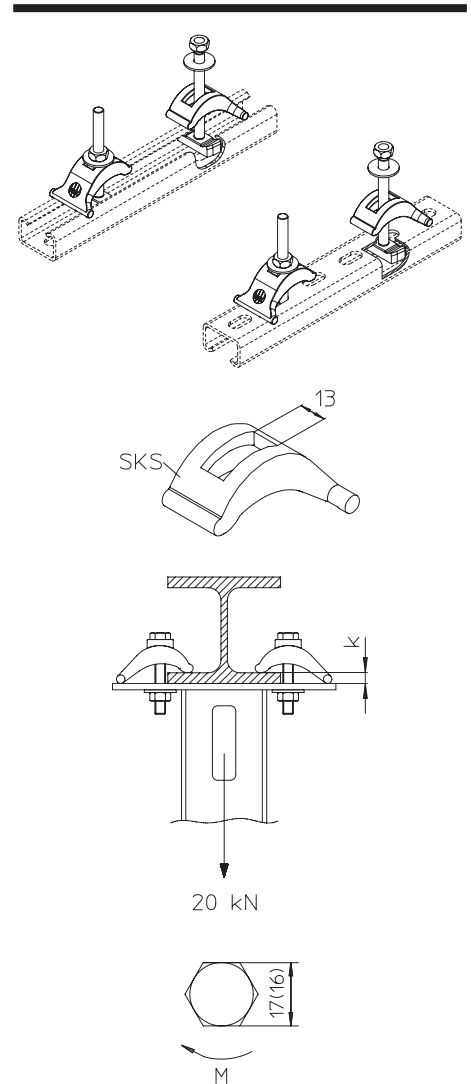

Fastenings

Clamping assembly

SKS A beam clamp set

For an application example, see the chapter assembly.

article number	k mm	P _{max} kN	M Nm	G kg/set
F				
SKS AF	10 - 30	20	50	0,56

accessories included:

2 x SES 10x75F	hexagon head bolt, DIN 933	(page H38)
2 x US 10x30F	square washer, DIN 9021	(page H40)
2 x AM22 M10F	channel nut, A41/ KHA 41/ KHAL 41	(page H43)
2 x UVS M10x24	captive washer	(page H40)

article number	k mm	P _{max} kN	M Nm	G kg/set
E4				
SKS AE4	10 - 30	20	50	0,59

accessories included:

2 x SES 10x75E4	hexagon head bolt, DIN 933	(page H38)
2 x US 10x30E4	square washer, DIN 9021	(page H40)
2 x UVS M10x24	captive washer	(page H40)
2 x AM22 M10E4	channel nut, A41/ KHA 41/ KHAL 41	(page H43)

accessories optional:

A 41	C-rail, not perforated, 41x41 mm	(page F62)
KHA 41	C-rail, perforated, 41x41 mm	(page F48)

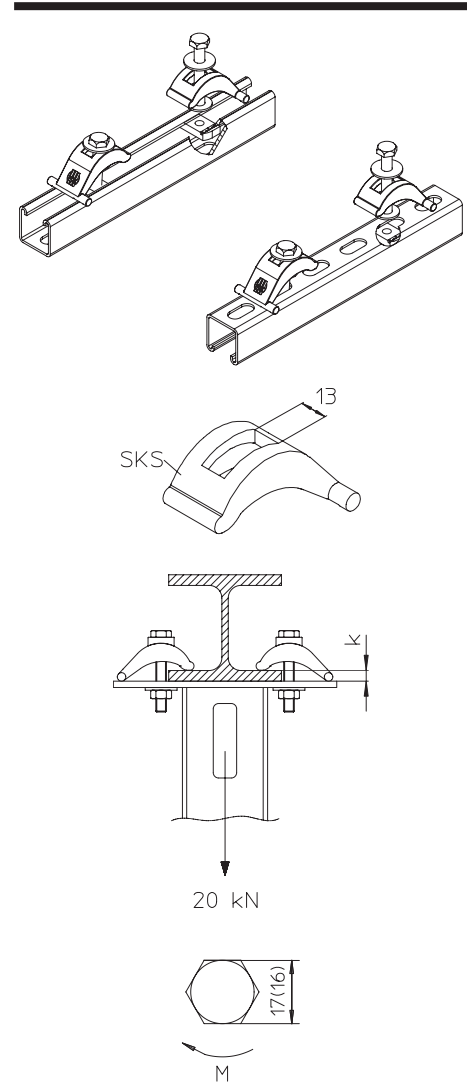

Fastenings

Clamping assembly

SKS M beam clamp set

article number	k mm	P _{max} kN	M Nm	G kg/set
F				
SKS MF	10 - 30	20	50	0,52

accessories included:

2 x SES 10x75F	hexagon head bolt, DIN 933	(page H38)
4 x US 10x30F	square washer, DIN 9021	(page H40)
2 x UVS M10x24	captive washer	(page H40)
2 x SEM 10F	hexagon-nut, DIN 934	(page H41)

article number	k mm	P _{max} kN	M Nm	G kg/set
E4				
SKS ME4	10 - 30	20	50	0,3

accessories included:

2 x SES 10x75E4	hexagon head bolt, DIN 933	(page H38)
4 x US 10x30E4	square washer, DIN 9021	(page H40)
2 x UVS M10x24	captive washer	(page H40)
2 x SEM 10E4	hexagon-nut, DIN 934	(page H41)

accessories optional:

KISS bracket, very heavy (page F10)

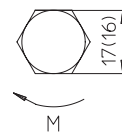
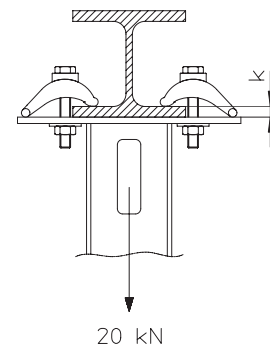
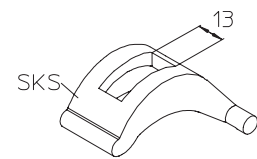
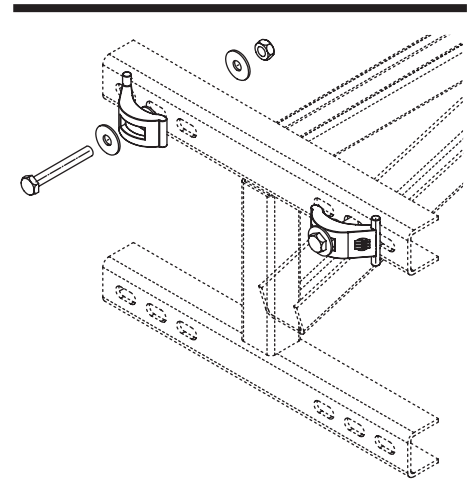

Fastenings

Clamping assembly

SKLC M beam clamp set

For an application example, see the chapter assembly.

article number	k mm	P _{max} kN	M Nm	G kg/set
F				
SKLC M-HDG	5 - 25	10	35	0,45

accessories included:

2 x SES 10x55F	hexagon head bolt, DIN 933	(page H38)
2 x US 10x21F	square washer, DIN 125	(page H39)
2 x US 10x30F	square washer, DINH4021	(page H40)
2 x SEM 10F	hexagon-nut, DIN 934	(page H41)
2 x UVS M10x24	captive washer	(page G40)

accessories optional:

KDU 60	bracket support, heavy, 60x40 mm	(page F21)
KHA 2	C-rail, perforated, 50x31 mm	(page F57)
HS22	tee-head bolt, A2/ A4	(page H43)

article number	k mm	P _{max} kN	M Nm	G kg/set
E4				
SKLC M-316	5 - 25	10	35	0,45

accessories included:

2 x SES 10x55F	hexagon head bolt, DIN 933	(page H38)
2 x US 10x21F	square washer, DIN 125	(page H39)
2 x US 10x30F	square washer, DIN 9021	(page H40)
2 x SEM 10F	hexagon-nut, DIN 934	(page H41)
2 x UVS M10x24	captive washer	(page H40)

accessories optional:

KDU 60	bracket support, heavy, 60x40 mm	(page F21)
KHA 2	C-rail, perforated, 50x31 mm	(page F57)
HS22	tee-head bolt, A2/ A4	(page H43)

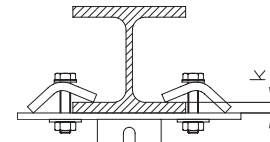
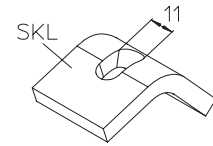
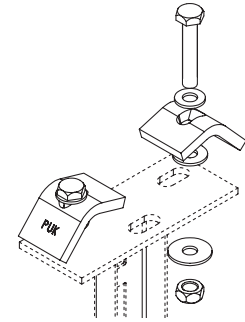

10 kN

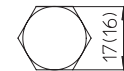

M

Fastenings

Clamping assembly

SKL A beam clamp set

For an application example, see the chapter assembly.

article number	k mm	P _{max} kN	M Nm	G kg/set
F				
SKL AF	5 - 25	10	35	0,49

accessories included:

2 x SES 10x55F	hexagon head bolt, DIN 933	(page H38)
2 x US 10x21F	square washer, DIN 125	(page H39)
2 x AM22 M10F	channel nut, A41/ KHA 41/ KHAL 41	(page H43)
2 x UVS M10x24	captive washer	(page H40)

accessories optional:

A 41	C-rail, not perforated, 41x41 mm	(page F62)
KHA 41	C-rail, perforated, 41x41 mm	(page F48)
KHAL 41	C-rail, perforated, 41x41 mm	(page F64)

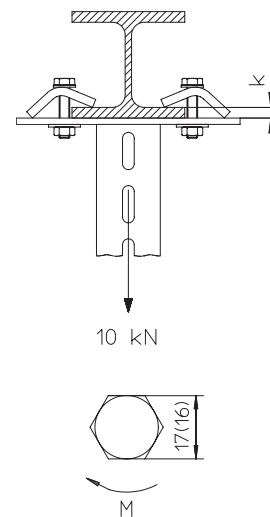
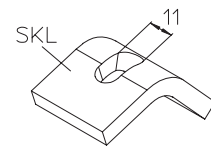
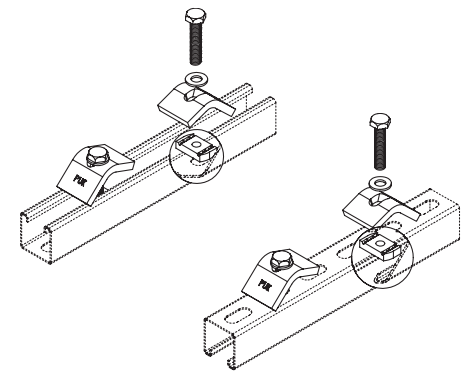

KLU fixing set

For an application example, see the chapter assembly.

article number	G kg/100
S	
KLU	2,5

accessories included:

2 x FRSV 6x16	round-head screw with short square	(page H34)
2 x SEMS 6	hexagon nut, self-locking, DIN 6923	(page H41)

accessories optional:

FRSV	round-head screw with short square	(page H34)
FRS	round-head screw with square, DIN 603	(page H35)
SEMS	hexagon nut, self-locking, DIN 6923	(page H41)

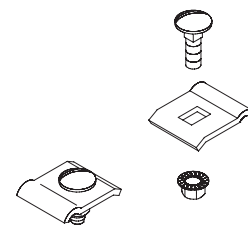

Fastenings

Clamping assembly

KLU fixing set

For an application example, see the chapter assembly.

article number	G
	kg/100
F	
KLU F	2,5
E	
KLU E	2,5

accessories included:

- 2 x **SEMS 6E** hexagon nut, self-locking, DIN 6923 (page H41)
- 2 x **FRSV 6x16E** round-head screw with short square (page H35)

article number	G
	kg/100
E4	
KLU E4	2,5

accessories included:

- 2 x **FKS 6x16E4** slotted cylinder head screw, DIN 84 (page H36)
- 2 x **US 6x12E4** square washer, DIN 125 (page H40)
- 2 x **SEM 6E4** hexagon-nut, DIN 934 (page H41)

accessories optional:

- FRSV** round-head screw with short square (page H34)
- FRS** round-head screw with square, DIN 603 (page H35)
- SEMS** hexagon nut, self-locking, DIN 6923 (page H41)

KLUS clamping assembly

For an application example, see the chapter assembly.

article number	G
	kg/100
S	
KLUS	9,3

accessories included:

- 2 x **FRSV 6x16** round-head screw with short square (page H34)
- 2 x **SEMS 6** hexagon nut, self-locking, DIN 6923 (page H41)

article number	G
	kg/100
E	
KLUS E	8,1

accessories included:

- 2 x **FRSV 6x16E** round-head screw with short square (page H35)
- 2 x **SEMS 6E** hexagon nut, self-locking, DIN 6923 (page H41)

accessories optional:

- FRSV** round-head screw with short square (page H34)
- FRS** round-head screw with square, DIN 603 (page H35)
- SEMS** hexagon nut, self-locking, DIN 6923 (page H41)

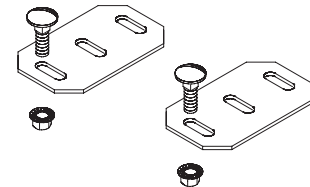
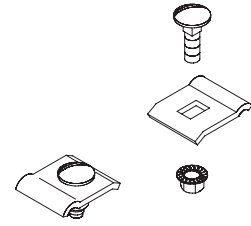

Fastenings

Clamping assembly

KLUT clamping assembly

article number	G
	kg/100
F	
KLUT F	12,4

article number	G
	kg/100
E	
KLUT E	11,2

accessories included:
 1 x **SES 8x30E** hexagon head bolt, DIN 933 (page H38)

article number	G
	kg/100
E4	
KLUT E4	11,2

accessories included:
 1 x **SES 8x30E4** hexagon head bolt, DIN 933 (page H38)

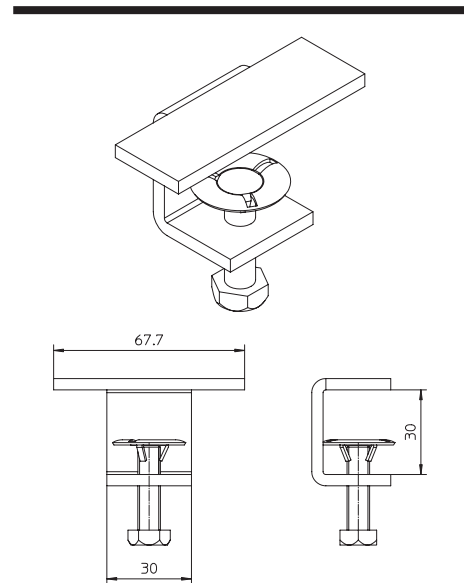

MKD beam clamp

For an application example, see the chapter assembly.

article number	B mm	Ø mm	K mm	P kN	M nM	G kg/100
F						
MKD 21	44	M8	6-21	1.50	4	19
MKD 21 M6	44	M6	6-21	1.50	4	18
MKD 21 M10	44	M10	6-21	1.50	4	17.3
MKD 40	44	M8	20-40	1.30	4	20.4
E						
MKD 21E	44	M8	6-21	1.50	4	19
MKD 21E M6	44	M6	6-21	1.50	4	18
MKD 21E M10	44	M10	6-21	1.50	4	17.3
MKD 40E	44	M8	20-40	1.30	4	19.3
E4						
MKD 21E4	44	M8	6-21	1.50	4	19
MKD 40E4	44	M8	20-40	1.30	4	19.3

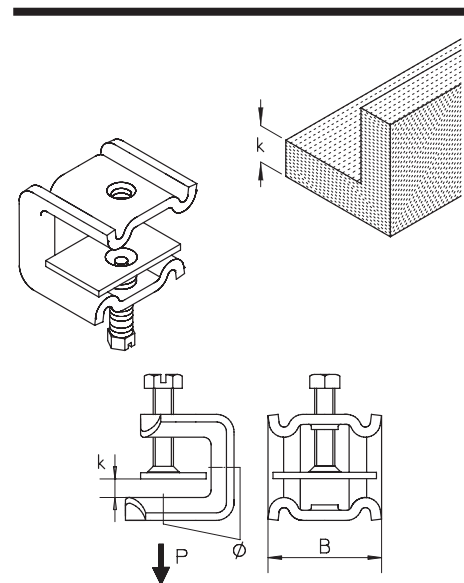

Fastenings

Clamping assembly

SN G beam clamp

For an application example, see the chapter assembly.

article number	H mm	D mm	G kg
F			
SN 25 M/G	25	M 8	0,04
SN 35 M/G	35	M 8	0,05
SN 25 O/G	25	8,5	0,04
SN 35 O/G	35	8,5	0,05

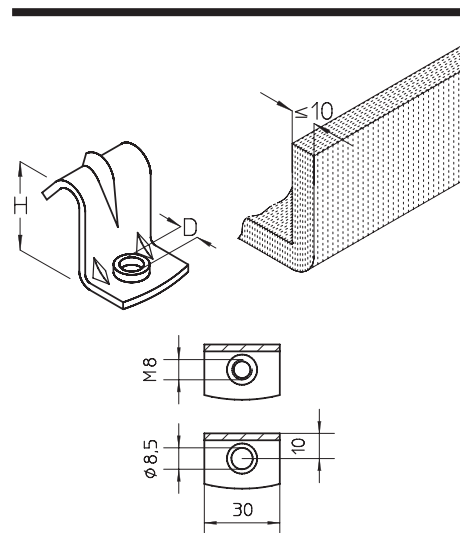

SK clamping claw

For an application example, see the chapter assembly.

article number	H mm	D mm	G kg
F			
SK 4 M8	4	M 8	0,04
SK 6 M8	6	M 8	0,04
SK 8 M8	8	M 8	0,04
SK 10 M8	10	M 8	0,04
SK 12 M8	12	M 8	0,04

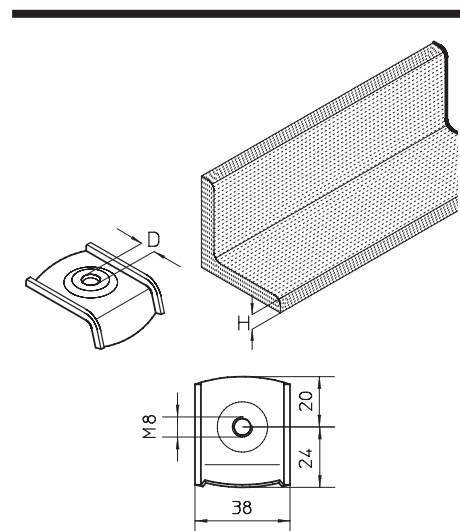

Fastenings

Clamping assembly

AN support

For an application example, see the chapter assembly.

article number	B mm	G kg
F		
AN 100	100	8,00

accessories optional:

B	cable clamp for fastening to profile rails	(catalogue cable clamps)
HB	cable clamp for fastening to profile rails	(catalogue cable clamps)
ACF-E	cable clamp for fastening to C-profiles	(catalogue cable clamps)

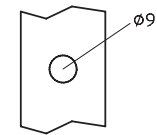
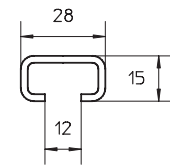
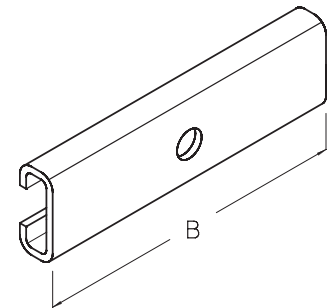

RGW reducing bolt

For an application example, see the chapter assembly.

article number	G kg
Z	
RGW 8/6	0,01
E	
RGW 8/6E	0,01

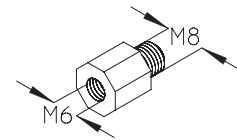

Fastenings

Plugs

SD expansion anchor

Manufacturer's information has to be observed strictly (ETA-05/0069). *Permissible load for a single anchor in cracked normal concrete (concrete tension zone) with a consistency of $\geq C20/25$
For an application example, see the chapter assembly.

article number	\varnothing mm	D mm	t mm	P_{zul} kN	L_{min} mm	G kg/100
GV						
SDK 10/10	10	10	0-10	4,3	55	5,88
SD 8/10	8	8	0 - 10	3,6	55	3,50
SD 8/30	8	8	0 - 30	3,6	55	4,40
SD 10/10	10	10	0 - 10	5,7	75	6,20
SD 10/30	10	10	0 - 30	5,7	75	7,80
SD 12/10	12	12	0 - 10	9,5	90	11,00
SD 16/25	16	16	0 - 25	13,4	110	26,30
E4						
SD 8/10E4	8	8	0 - 10	3,6	55	3,60
SD 10/10E4	10	10	0 - 10	5,7	75	6,20
SD 12/10E4	12	12	0 - 10	9,5	90	10,90

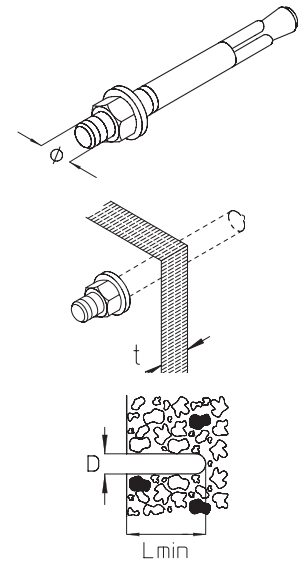

SAZ anchor

Manufacturer's information has to be observed strictly (ETA-06/0271). *Permissible load for a single anchor in cracked normal concrete (concrete tension zone) with a consistency of $\geq C20/25$

article number	\varnothing mm	D mm	L mm	P_{zul} kN	L_{min} mm	G kg/100
GV						
SAZ 6	6	12	8 - 13	2,4	43	3,2
SAZ 8	8	10	11 - 17	1,6	43	1,4
SAZ 10	10	12	13 - 19	3,0	43	1,9
SAZ 12	12	14	15 - 21	3,6	43	2,6
E4						
SAZ 8E4	8	10	11 - 17	1,6	43	1,4
SAZ 10E4	10	12	13 - 19	3,0	43	1,9
SAZ 12E4	12	14	15 - 21	3,6	43	2,6

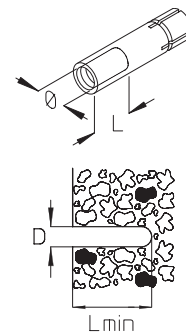

SAZ-B Ferro-concrete drill

manufacturer's information has to be observed strictly.

article number	G kg/100
GV	
SAZ-B 8	8,2
SAZ-B 10	14,0
SAZ-B 12	20,0



Fastenings Plugs

SAZ-D anchor

manufacturer's information has to be observed strictly.

article number	Ø mm	G kg/100
GV		
SAZ-D 8	8	44,4
SAZ-D 10	10	45,0
SAZ-D 12	12	45,2

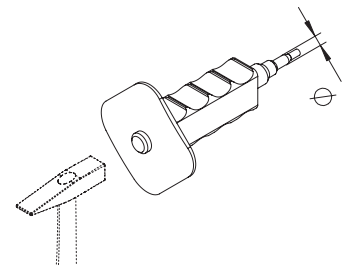

SA-D anchor

manufacturer's information has to be observed strictly.

article number	Ø mm	G kg/100
GV		
SA-D 8	8	49,5
SA-D 10	10	50,5
SA-D 12	12	51,0

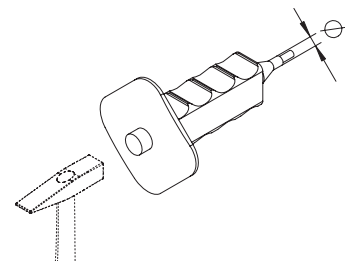

SA anchor

Manufacturer's information has to be observed strictly (ETA-07/0135). *Permissible load for a single anchor in non-cracked normal concrete (compressive concrete zone) with a consistency of $\geq C20/25$

article number	Ø mm	D mm	L mm	P _{zul} * kN	L _{min} mm	G kg/100
GV						
SA 6	6	8	6 - 12	3,95	27	0,4
SA 8	8	10	11 - 17	3,95	33	0,5
SA 10	10	12	13 - 19	6,10	44	0,8
SA 12	12	15	15 - 21	8,50	54	1,6
E4						
SA 6E4	6	8	6 - 12	3,95	27	0,4
SA 8E4	8	10	11 - 17	3,95	33	0,5
SA 10E4	10	12	13 - 19	6,10	44	0,8
SA 12E4	12	15	15 - 21	8,50	54	1,6

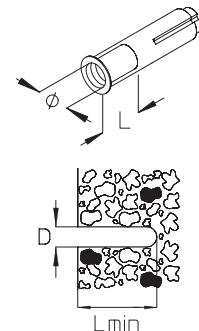

KD plastic dowel

manufacturer's information has to be observed strictly.

article number	Ø mm	D mm	L _{min} mm	G kg/100
PA				
KD 6	6	8	55	0,2
KD 8	8	10	70	0,3
KD 10	10	12	80	0,5
KD 12	12	14	95	0,7

accessories optional:

SEH hexagon wood screw (page H38)

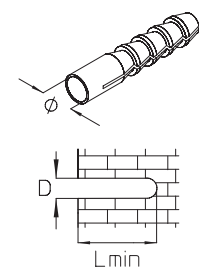

Fastenings Plugs

VAB-HB shear connector rod, concrete

Manufacturer's information has to be observed strictly (ETA-05/0164). *Permissible load for a single anchor in cracked normal concrete (concrete tension zone) with a consistency of \geq C20/25

article number	\varnothing mm	D mm	t mm	P_{zul} kN	L_{min} mm	G kg/100
GV						
VAB-HB 10/20	10	10	0 - 20	8	75	6,7
VAB-HB 12/25	12	12	0 - 25	11,1	90	11,9
VAB-HB 16/30	16	16	0 - 30	15,9	110	30,0
E4						
VAB-HB 10/20E4	10	10	0 - 20	8	75	6,9
VAB-HB 12/25E4	12	12	0 - 25	11,1	90	12,0
VAB-HB 16/30E4	16	16	0 - 30	15,9	110	30,2

accessories optional:

VAB-HB M shear connector mortar (page H14)

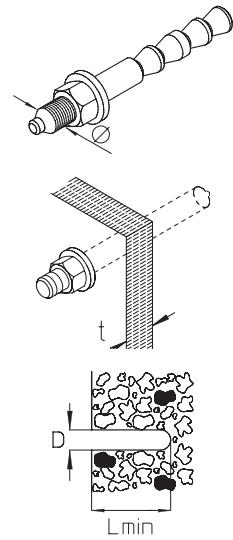

VAB-HB B shear connector rod, brush

manufacturer's information has to be observed strictly. 40-50 dowels per cartridge

article number	G kg
VAB-HB B10	0,03
VAB-HB B12	0,04
VAB-HB B16	0,08



VAB-HB M shear connector mortar

manufacturer's information has to be observed strictly. Dowels per cartridge in concrete: VAS-HB 10/20 approx. 40x; VAS-HB 12/25 approx. 34x; VAS-HB 16/30 approx. 21x

article number	G kg/100
VAB-HB M	23

accessories optional:

VA-AP shear connector rod, pistol (page H14)

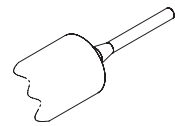

VA-AP shear connector rod, pistol

manufacturer's information has to be observed strictly.

article number	G kg
VA-AP	1,15

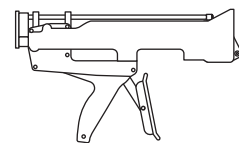

Fastenings

Plugs

VAS-AS shear connector rod, stone

Manufacturer's information has to be observed strictly (Z-21.3-1824). load specifications are dependent on the ground. 30-40 dowels per cartridge

article number	Ø mm	D mm	t mm	L _{min} mm	G kg/100
GV					
VAS-AS 8/15	8	10	0 - 15	80	4,2
VAS-AS 10/25	10	12	0 - 25	80	7,0
VAS-AS 12/40	12	14	0 - 40	80	11,8
E4					
VAS-AS 8/15E4	8	10	0 - 15	80	4,2
VAS-AS 10/25E4	10	12	0 - 25	80	7,2
VAS-AS 12/40E4	12	14	0 - 40	80	12,1

accessories optional:

VAS-BS	shear connector rod, fire protection	(page H15)
VAS-M	shear connector mortar	(page H15)
VAS-SH	perforated bush for shear connector, stone	(page H15)

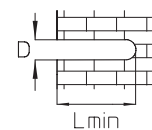
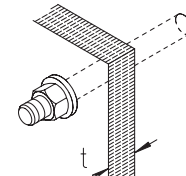
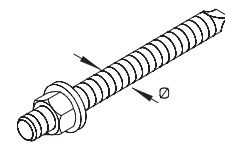

VAS-BS shear connector rod, fire protection

manufacturer's information has to be observed strictly.

article number	G kg
GV	
VAS-BS 14/20	10,30

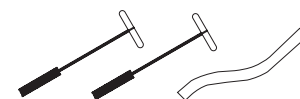

VAS-SH perforated bush for shear connector, stone

manufacturer's information has to be observed strictly.

article number	G kg/100
GV	
VAS-SH	0,2

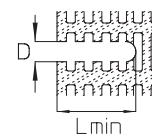
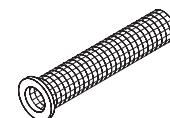

VAS-M shear connector mortar

manufacturer's information has to be observed strictly. Dowels per cartridge in solid brick: VAS-AS 8/15 approx. 50x; VAS-AS 10/25 approx. 40x; VAS-AS 12/40 approx. 30x Dowels per cartridge in perforated brick: VAS-AS + VAS-SH approx. 14x

article number	G kg/100
GV	
VAS-M	67,2

accessories optional:

VA-AP	shear connector rod, pistol	(page H14)
--------------	-----------------------------	------------

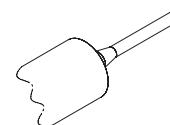

Fastenings

Suspension components

TBS trapezium bow

manufacturer's information has to be observed strictly. For hanging direct in trapeze profile.
 For an application example, see the chapter assembly.
 For assembly instructions, see the chapter assembly.

article number	Ø mm	P _{zul} kN	G kg/100
TBS 8	8	1,3	0,14
TBS 10	10	1,3	0,14

accessories included:

1 x **SES 8x110** hexagon head bolt, DIN 933 (page H37)
 1 x **SEM 8** hexagon-nut, DIN 934 (page H41)

accessories optional:

HFEF8EXP 2 wire suspension with threaded end M8 and express closure (page H20)
HFEF8 3 wire suspension with threaded end M8 and universal closure (page H20)
HFEF10EXP 2 wire suspension with threaded end M10 and express closure (page H20)
HFEF10 3 wire suspension with threaded end M10 and universal closure (page H21)
HFEF10 4 wire suspension with threaded end M10 and universal closure (page H21)

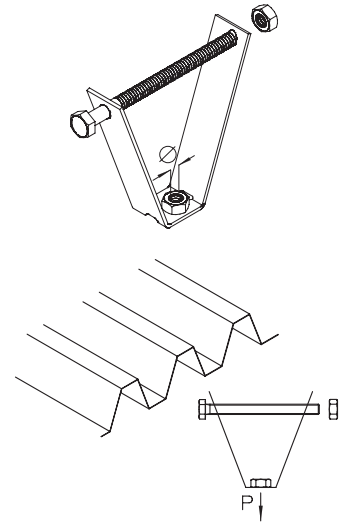

GB threaded rod, DIN 976-1

Stress-areas according to DIN 267 T4: GB M8 = 36.6 mm², GB M10 = 58.0 mm², GB M12 = 84.3 mm²
 For an application example, see the chapter assembly.

article number	Ø mm	L mm	G kg
GV			
GB M8-03	8	300	0,09
GB M8-05	8	500	0,15
GB M8-10	8	1000	0,30
GB M10-03	10	300	0,15
GB M10-05	10	500	0,25
GB M10-10	10	1000	0,50
GB M12-03	12	300	0,21
GB M12-05	12	500	0,35
GB M12-10	12	1000	0,70

E			
GB M8-10E	8	1000	0,30
GB M10-10E	10	1000	0,50
GB M12-10E	12	1000	0,70

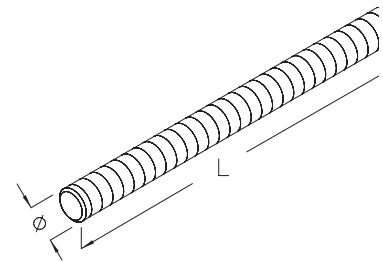

VM rod coupling

article number	Ø mm	L mm	G kg
GV			
VM M8	8	30	0,01
VM M10	10	30	0,03
VM M12	12	30	0,05

E			
VM M8E	8	30	0,01
VM M10E	10	30	0,03
VM M12E	12	30	0,05

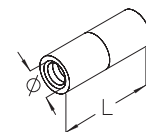

Fastenings

Suspension components

KNK chain

Chain elongation app. 0,1 x length.
For an application example, see the chapter assembly.

article number	t mm	G kg/m
GV		
KNK	3	0,2

accessories optional:
KNK-NG chain, emergency link (page H17, K05)

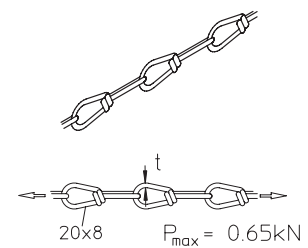

KNK-NG chain, emergency link

For an application example, see the chapter assembly.

article number	t mm	G kg/100
GV		
KNK-NG	3	0,36



DAS wire eyebolt

For an application example, see the chapter assembly.

article number	Ø mm	L mm	t mm	P _{max} kN	G kg
DAS 8x30	8	30	7	0,5	0,02

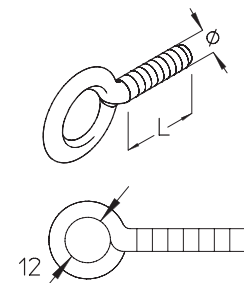

SHS eyebolt

For an application example, see the chapter assembly.

article number	Ø mm	L mm	t mm	G kg
GV				
SHS 6x40	6	40	5,2	0,02
SHS 8x45	8	45	7,0	0,03

accessories optional:
KNK chain (page H17, K05)

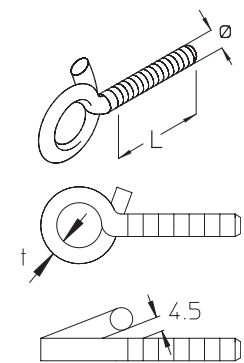

P_{max} = 0,4 kN

Fastenings

Suspension components

SHH eyebolt

For an application example, see the chapter assembly.

article number	Ø mm	L mm	t mm	G kg
GV				
SHH 6x40	6	40	5,2	0,02

accessories optional:

KNK chain (page H17, K05)

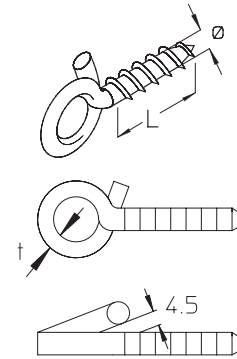

$P_{max} = 0,4 \text{ kN}$

HFCEXP 1 wire suspension with hook and express closure

article number	L mm	P_{max} kg	Gripple load class	G kg
GV				
HFCEXP 11GV	1000	15	1	0,06
HFCEXP 12GV	2000	15	1	0,06
HFCEXP 13GV	3000	15	1	0,06
HFCEXP 14GV	4000	15	1	0,08
HFCEXP 15GV	5000	15	1	0,09
HFCEXP 110GV	10000	15	1	0,09

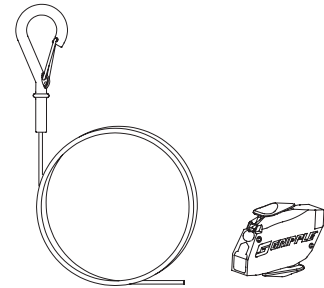

HFCEXP 2 wire suspension with hook and express closure

article number	L mm	P_{max} kg	Gripple load class	G kg
GV				
HFCEXP 21GV	1000	45	2	0,06
HFCEXP 22GV	2000	45	2	0,08
HFCEXP 23GV	3000	45	2	0,09
HFCEXP 24GV	4000	45	2	0,13
HFCEXP 25GV	5000	45	2	0,14
HFCEXP 210GV	10000	45	2	0,21

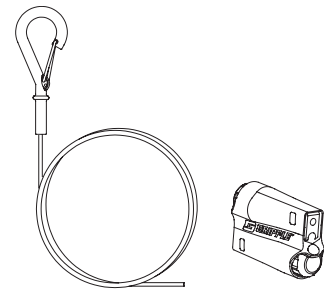

HFEC 3 wire suspension with hook and universal closure

article number	L mm	P_{max} kg	Gripple load class	G kg
GV				
HFEC 31GV	1000	90	3	0,08
HFEC 32GV	2000	90	3	0,13
HFEC 33GV	3000	90	3	0,16
HFEC 34GV	4000	90	3	0,20
HFEC 35GV	5000	90	3	0,24
HFEC 310GV	1000	90	3	0,43

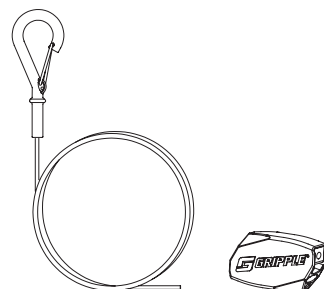

Fastenings

Suspension components

HFEF6EXP 1 wire suspension with threaded end M6 and express closure

article number	L mm	P _{max} kg	Gripple load class	G kg
GV				
HFEF6EXP 11GV	1000	15	1	0,04
HFEF6EXP 12GV	2000	15	1	0,06
HFEF6EXP 13GV	3000	15	1	0,06
HFEF6EXP 14GV	4000	15	1	0,06
HFEF6EXP 15GV	5000	15	1	0,07
HFEF6EXP 110GV	10000	15	1	0,12

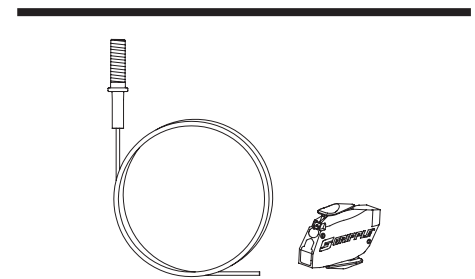

HFEF6EXP 2 wire suspension with threaded end M6 and express closure

article number	L mm	P _{max} kg	Gripple load class	G kg
GV				
HFEF6EXP 21GV	1000	45	2	0,06
HFEF6EXP 22GV	2000	45	2	0,08
HFEF6EXP 23GV	3000	45	2	0,10
HFEF6EXP 24GV	4000	45	2	0,11
HFEF6EXP 25GV	5000	45	2	0,13
HFEF6EXP 210GV	10000	45	2	0,22

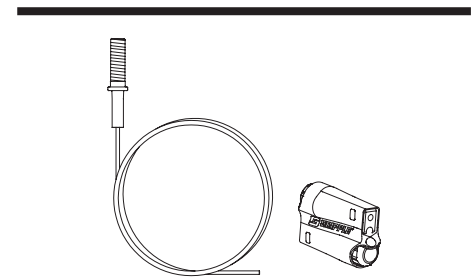

HFEF6 2 wire suspension with threaded end M6 and universal closure

article number	L mm	P _{max} kg	Gripple load class	G kg
E2				
HFEF6 21E2	1000	45	2	0,05
HFEF6 22E2	2000	45	2	0,07
HFEF6 23E2	3000	45	2	0,08
HFEF6 24E2	4000	45	2	0,09
HFEF6 25E2	5000	45	2	0,10
HFEF6 210E2	10000	45	2	0,18

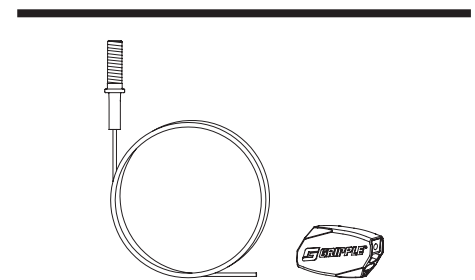

HFEF6 3 wire suspension with threaded end M6 and universal closure

article number	L mm	P _{max} kg	Gripple load class	G kg
GV				
HFEF6 31GV	1000	90	3	0,06
HFEF6 32GV	2000	90	3	0,10
HFEF6 33GV	3000	90	3	0,14
HFEF6 34GV	4000	90	3	0,18
HFEF6 35GV	5000	90	3	0,22
HFEF6 310GV	10000	90	3	0,42

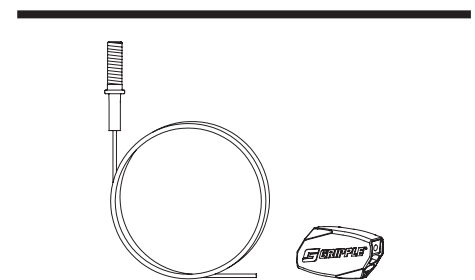

Fastenings

Suspension components

HFEF8EXP 2 wire suspension with threaded end M8 and express closure

article number	L mm	P _{max} kg	Gripple load class	G kg
GV				
HFEF8EXP 21GV	1000	45	2	0,08
HFEF8EXP 22GV	2000	45	2	0,09
HFEF8EXP 23GV	3000	45	2	0,11
HFEF8EXP 24GV	4000	45	2	0,13
HFEF8EXP 25GV	5000	45	2	0,14
HFEF8EXP 210GV	10000	45	2	0,23

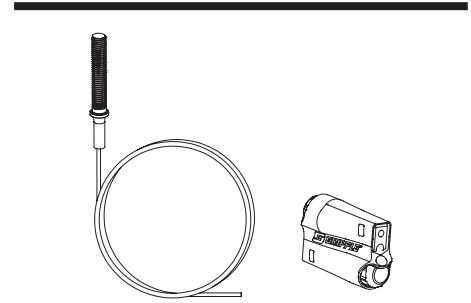

HFEF8 2 wire suspension with threaded end M8 and universal closure

article number	L mm	P _{max} kg	Gripple load class	G kg
E2				
HFEF8 21E2	1000	45	2	0,05
HFEF8 22E2	2000	45	2	0,07
HFEF8 23E2	3000	45	2	0,08
HFEF8 24E2	4000	45	2	0,09
HFEF8 25E2	5000	45	2	0,10
HFEF8 210E2	10000	45	2	0,18

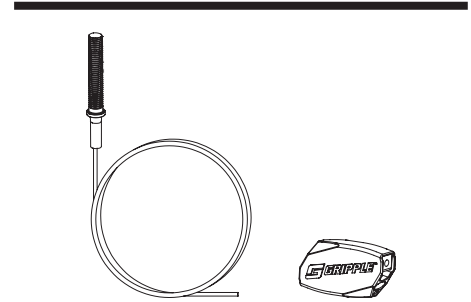

HFEF8 3 wire suspension with threaded end M8 and universal closure

article number	L mm	P _{max} kg	Gripple load class	G kg
GV				
HFEF8 31GV	1000	90	3	0,10
HFEF8 32GV	2000	90	3	0,14
HFEF8 33GV	3000	90	3	0,18
HFEF8 34GV	4000	90	3	0,22
HFEF8 35GV	5000	90	3	0,26
HFEF8 310GV	10000	90	3	0,42
E2				
HFEF8 31E2	1000	90	3	0,08
HFEF8 32E2	2000	90	3	0,11
HFEF8 33E2	3000	90	3	0,14
HFEF8 34E2	4000	90	3	0,18
HFEF8 35E2	5000	90	3	0,20
HFEF8 310E2	10000	90	3	0,37

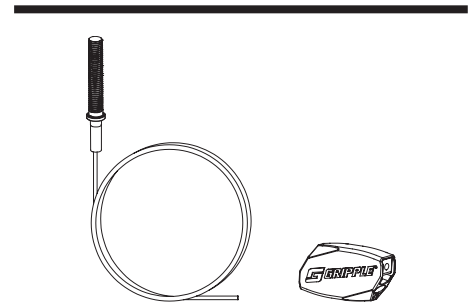

HFEF10EXP 2 wire suspension with threaded end M10 and express closure

article number	L mm	P _{max} kg	Gripple load class	G kg
GV				
HFEF10EXP 21GV	1000	45	2	0,08
HFEF10EXP 22GV	2000	45	2	0,09
HFEF10EXP 23GV	3000	45	2	0,11
HFEF10EXP 24GV	4000	45	2	0,13
HFEF10EXP 25GV	5000	45	2	0,14
HFEF10EXP 210GV	10000	45	2	0,23

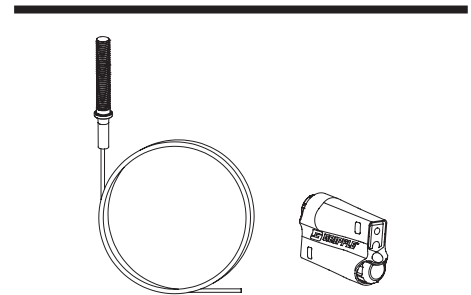

Fastenings

Suspension components

HFEF10 3 wire suspension with threaded end M10 and universal closure

article number	L mm	P _{max} kg	Gripple load class	G kg
GV				
HFEF10 31GV	1000	90	3	0,10
HFEF10 32GV	2000	90	3	0,14
HFEF10 33GV	3000	90	3	0,17
HFEF10 34GV	4000	90	3	0,21
HFEF10 35GV	5000	90	3	0,25
HFEF10 310GV	10000	90	3	0,42

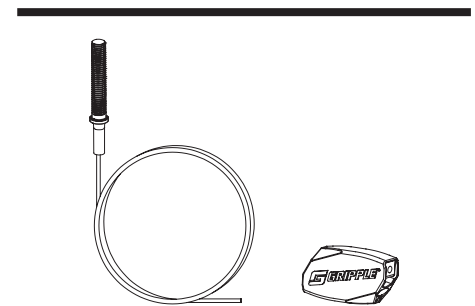

HFEF10 4 wire suspension with threaded end M10 and universal closure

article number	L mm	P _{max} kg	Gripple load class	G kg
GV				
HFEF10 41GV	1000	225	4	0,21
HFEF10 42GV	2000	225	4	0,30
HFEF10 43GV	3000	225	4	0,39
HFEF10 44GV	4000	225	4	0,47
HFEF10 45GV	5000	225	4	0,55
HFEF10 410GV	10000	225	4	0,99

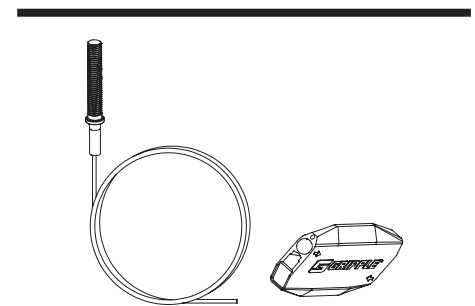

HFEM 2 wire suspension with carbine and universal closure

article number	L mm	P _{max} kg	Gripple load class	G kg
E4				
HFEM 21E4	1000	45	2	0,05
HFEM 22E4	2000	45	2	0,07
HFEM 23E4	3000	45	2	0,08
HFEM 24E4	4000	45	2	0,09
HFEM 25E4	5000	45	2	0,10
HFEM 210E4	10000	45	2	0,18

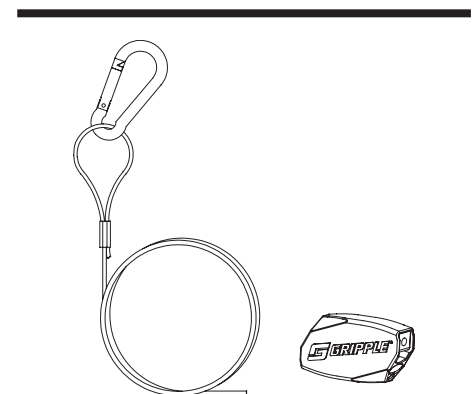

HFEM 3 wire suspension with carbine and universal closure

article number	L mm	P _{max} kg	Gripple load class	G kg
E4				
HFEM 31E4	1000	90	3	0,08
HFEM 32E4	2000	90	3	0,11
HFEM 33E4	3000	90	3	0,14
HFEM 34E4	4000	90	3	0,18
HFEM 35E4	5000	90	3	0,20
HFEM 310E4	10000	90	3	0,37

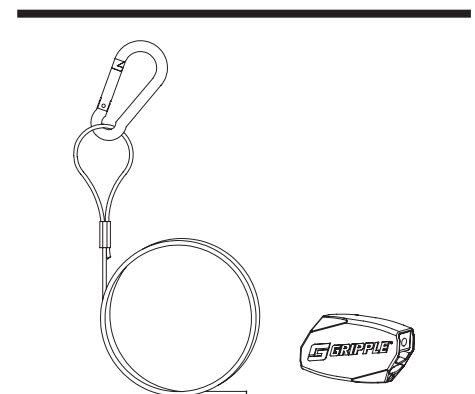

Fastenings

Suspension components

HFEOEXP 2 wire suspension with eyelet straight and express closure

article number	L mm	P _{max} kg	Gripple load class	G kg
GV				
HFEOEXP 21GV	1000	45	2	0,05
HFEOEXP 22GV	2000	45	2	0,07
HFEOEXP 23GV	3000	45	2	0,09
HFEOEXP 24GV	4000	45	2	0,10
HFEOEXP 25GV	5000	45	2	0,12
HFEOEXP 210GV	10000	45	2	0,20

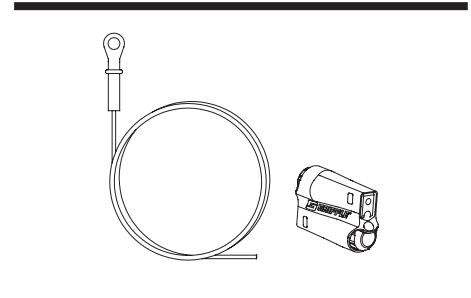

HFEO 3 wire suspension with eyelet straight and universal closure

article number	L mm	P _{max} kg	Gripple load class	G kg
GV				
HFEO 31GV	1000	90	3	0,08
HFEO 32GV	2000	90	3	0,13
HFEO 33GV	3000	90	3	0,16
HFEO 34GV	4000	90	3	0,21
HFEO 35GV	5000	90	3	0,38
HFEO 310GV	10000	90	3	0,45

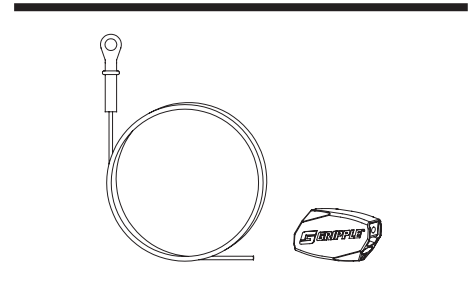

HFET6EXP 1 wire suspension with threaded transition M6 and express closure

article number	L mm	P _{max} kg	Gripple load class	G kg
GV				
HFET6EXP 11GV	1000	15	1	0,04
HFET6EXP 12GV	2000	15	1	0,06
HFET6EXP 13GV	3000	15	1	0,06
HFET6EXP 14GV	4000	15	1	0,06
HFET6EXP 15GV	5000	15	1	0,07
HFET6EXP 110GV	10000	15	1	0,12

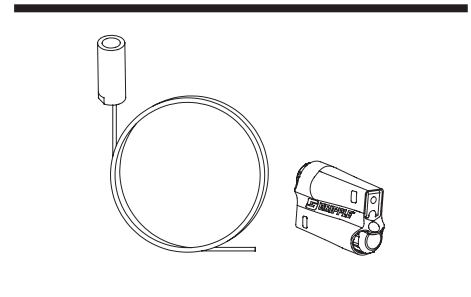

HFET6EXP 2 wire suspension with threaded transition M6 and express closure

article number	L mm	P _{max} kg	Gripple load class	G kg
GV				
HFET6EXP 21GV	1000	45	2	0,06
HFET6EXP 22GV	2000	45	2	0,08
HFET6EXP 23GV	3000	45	2	0,10
HFET6EXP 24GV	4000	45	2	0,11
HFET6EXP 25GV	5000	45	2	0,13
HFET6EXP 210GV	10000	45	2	0,22

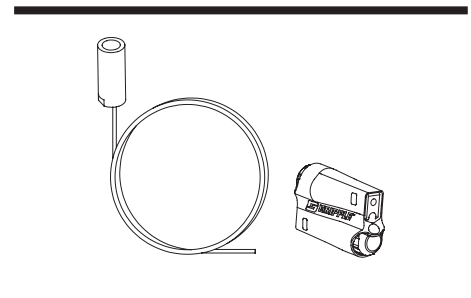

HFET8EXP 2 wire suspension with threaded transition M8 and express closure

article number	L mm	P _{max} kg	Gripple load class	G kg
GV				
HFET8EXP 21GV	1000	45	2	0,06
HFET8EXP 22GV	1000	45	2	0,08
HFET8EXP 23GV	1000	45	2	0,10
HFET8EXP 24GV	1000	45	2	0,11
HFET8EXP 25GV	1000	45	2	0,13
HFET8EXP 210GV	1000	45	2	0,22

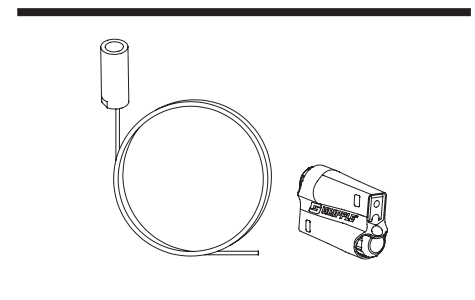

HFFREXP 1 wire suspension with loop and express closure

article number	L mm	P _{max} kg	Gripple load class	G kg
GV				
HFFREXP 11GV	1000	15	1	0,04
HFFREXP 12GV	2000	15	1	0,04
HFFREXP 13GV	3000	15	1	0,06
HFFREXP 14GV	4000	15	1	0,06
HFFREXP 15GV	5000	15	1	0,07
HFFREXP 110GV	10000	15	1	0,11

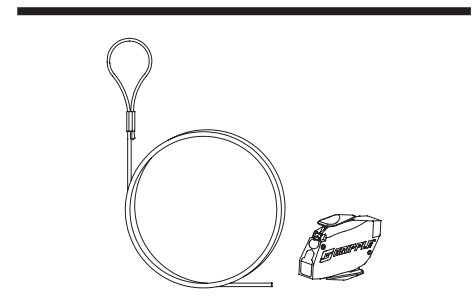

HFFREXP 2 wire suspension with loop and express closure

article number	L mm	P _{max} kg	Gripple load class	G kg
GV				
HFFREXP 21GV	1000	45	2	0,05
HFFREXP 22GV	2000	45	2	0,06
HFFREXP 23GV	3000	45	2	0,08
HFFREXP 24GV	4000	45	2	0,10
HFFREXP 25GV	5000	45	2	0,12
HFFREXP 210GV	10000	45	2	0,21

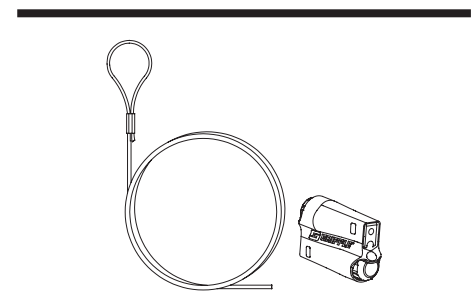

HFFR 2 wire suspension with loop and universal closure

article number	L mm	P _{max} kg	Gripple load class	G kg
E4				
HFFR 21E4	1000	45	2	0,03
HFFR 22E4	2000	45	2	0,05
HFFR 23E4	3000	45	2	0,07
HFFR 24E4	4000	45	2	0,10
HFFR 25E4	5000	45	2	0,10
HFFR 210E4	10000	45	2	0,18

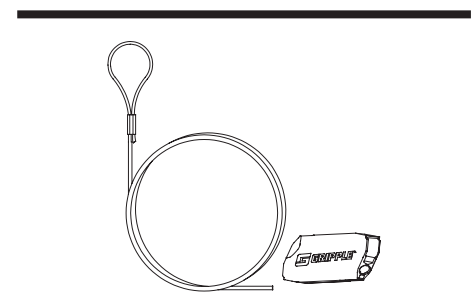

Fastenings

Suspension components

HFFR 3 wire suspension with loop and universal closure

article number	L mm	P _{max} kg	Gripple load class	G kg
GV				
HFFR 31GV	1000	90	3	0,08
HFFR 32GV	2000	90	3	0,12
HFFR 33GV	3000	90	3	0,16
HFFR 34GV	4000	90	3	0,18
HFFR 35GV	5000	90	3	0,22
HFFR 310GV	10000	90	3	0,39

E4				
HFFR 31E4	1000	90	3	0,08
HFFR 32E4	2000	90	3	0,11
HFFR 33E4	3000	90	3	0,14
HFFR 34E4	4000	90	3	0,18
HFFR 35E4	5000	90	3	0,20
HFFR 310E4	10000	90	3	0,37

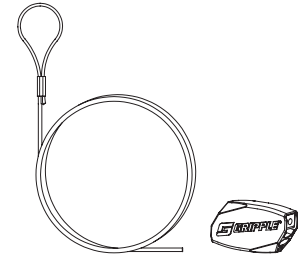

HFFR 4 wire suspension with loop and universal closure

article number	L mm	P _{max} kg	Gripple load class	G kg
GV				
HFFR 41GV	1000	225	4	0,22
HFFR 42GV	2000	225	4	0,29
HFFR 43GV	3000	225	4	0,39
HFFR 44GV	4000	225	4	0,45
HFFR 45GV	5000	225	4	0,61
HFFR 410GV	10000	225	4	1,09

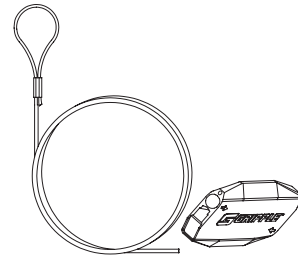

HFFR 5 wire suspension with loop and universal closure

article number	L mm	P _{max} kg	Gripple load class	G kg
GV				
HFFR 51GV	1000	325	5	0,40
HFFR 52GV	2000	325	5	0,70
HFFR 53GV	3000	325	5	0,73
HFFR 54GV	4000	325	5	0,89
HFFR 55GV	5000	325	5	1,08
HFFR 510GV	10000	325	5	1,88

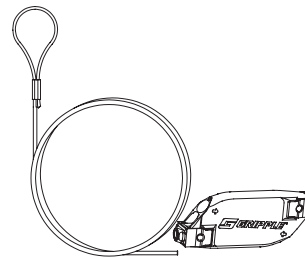

HFSPEXP 1 wire suspension with cross anchor and express closure

article number	L mm	P _{max} kg	Gripple load class	G kg
GV				
HFSPEXP 11GV	1000	15	1	0,04
HFSPEXP 12GV	2000	15	1	0,04
HFSPEXP 13GV	3000	15	1	0,06
HFSPEXP 14GV	4000	15	1	0,06
HFSPEXP 15GV	5000	15	1	0,07
HFSPEXP 110GV	10000	15	1	0,12

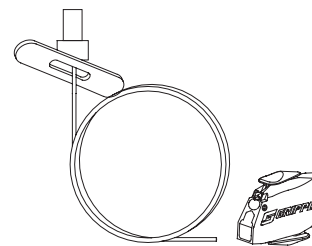

HFSP EXP 2 wire suspension with cross anchor and express closure

article number	L mm	P _{max} kg	Gripple load class	G kg
GV				
HFSP EXP 21GV	1000	45	2	0,05
HFSP EXP 22GV	2000	45	2	0,06
HFSP EXP 23GV	3000	45	2	0,08
HFSP EXP 24GV	4000	45	2	0,10
HFSP EXP 25GV	5000	45	2	0,12
HFSP EXP 210GV	10000	45	2	0,21

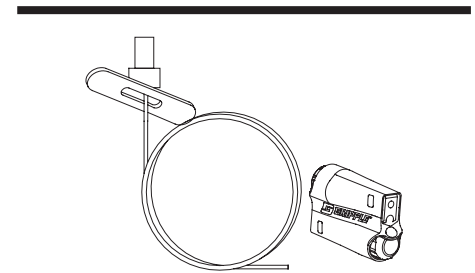

HFSP 2 wire suspension with cross anchor and universal closure

article number	L mm	P _{max} kg	Gripple load class	G kg
E2				
HFSP 21E2	1000	45	2	0,05
HFSP 22E2	2000	45	2	0,07
HFSP 23E2	3000	45	2	0,08
HFSP 24E2	4000	45	2	0,09
HFSP 25E2	5000	45	2	0,10
HFSP 210E2	10000	45	2	0,18

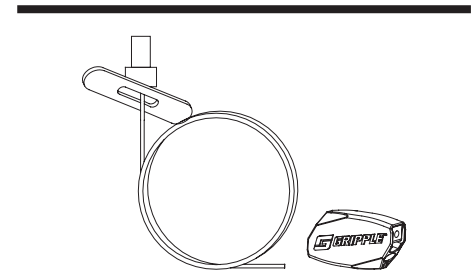

HFSP 3 wire suspension with cross anchor and universal closure

article number	L mm	P _{max} kg	Gripple load class	G kg
GV				
HFSP 31GV	1000	90	3	0,08
HFSP 32GV	2000	90	3	0,12
HFSP 33GV	3000	90	3	0,15
HFSP 34GV	4000	90	3	0,20
HFSP 35GV	5000	90	3	0,23
HFSP 310GV	10000	90	3	0,43

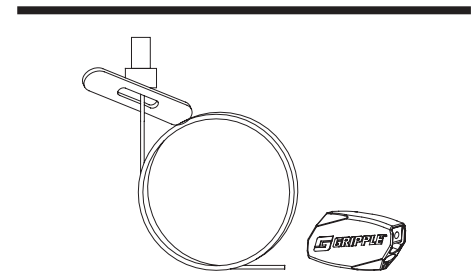

HFTHEXP 1 wire suspension with trapezium sheet metal hook and express closure

article number	L mm	P _{max} kg	Gripple load class	G kg
GV				
HFTHEXP 11GV	1000	15	1	0,04
HFTHEXP 12GV	2000	15	1	0,04
HFTHEXP 13GV	3000	15	1	0,06
HFTHEXP 14GV	4000	15	1	0,06
HFTHEXP 15GV	5000	15	1	0,07
HFTHEXP 110GV	10000	15	1	0,12

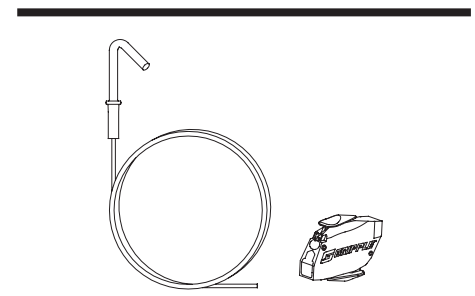

Fastenings

Suspension components

HFTHEXP 2 wire suspension with trapezium sheet metal hook and express closure

article number	L mm	P _{max} kg	Gripple load class	G kg
GV				
HFTHEXP 21GV	1000	45	2	0,05
HFTHEXP 22GV	2000	45	2	0,06
HFTHEXP 23GV	3000	45	2	0,08
HFTHEXP 24GV	4000	45	2	0,10
HFTHEXP 25GV	5000	45	2	0,12
HFTHEXP 210GV	10000	45	2	0,21

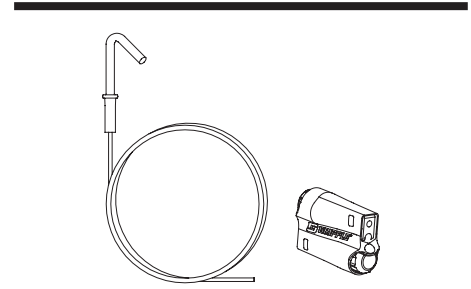

TPZPEC 2 wire suspension with hook and trapezium closure plus

article number	L mm	P _{max} kg	Gripple load class	G kg
GV				
TPZPEC 21GV	1000	45	2	0,14
TPZPEC 22GV	2000	45	2	0,16
TPZPEC 23GV	3000	45	2	0,17
TPZPEC 24GV	4000	45	2	0,20
TPZPEC 25GV	5000	45	2	0,22
TPZPEC 210GV	10000	45	2	0,28

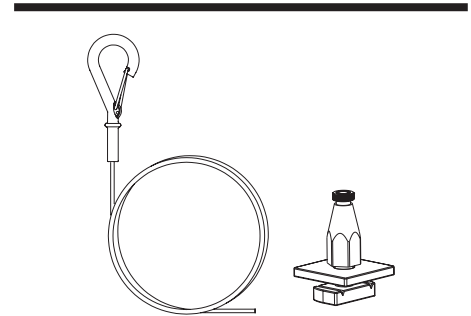

TPZPEC 3 wire suspension with hook and trapezium closure plus

article number	L mm	P _{max} kg	Gripple load class	G kg
GV				
TPZPEC 31GV	1000	90	3	0,14
TPZPEC 32GV	2000	90	3	0,18
TPZPEC 33GV	3000	90	3	0,21
TPZPEC 34GV	4000	90	3	0,25
TPZPEC 35GV	5000	90	3	0,29
TPZPEC 310GV	10000	90	3	0,48

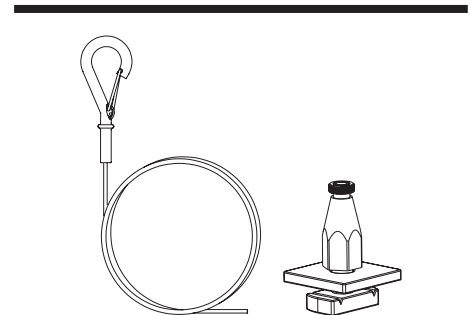

TPZPEF8 2 wire suspension with threaded end M8 and trapezium closure plus

article number	L mm	P _{max} kg	Gripple load class	G kg
GV				
TPZPEF8 21GV	1000	45	2	0,15
TPZPEF8 22GV	2000	45	2	0,17
TPZPEF8 23GV	3000	45	2	0,19
TPZPEF8 24GV	4000	45	2	0,20
TPZPEF8 25GV	5000	45	2	0,22
TPZPEF8 210GV	10000	45	2	0,31

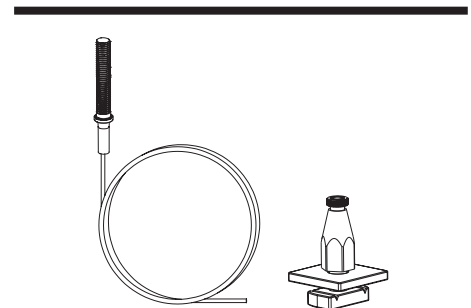

TPZPEF8 3 wire suspension with threaded end M8 and trapezium closure plus

article number	L mm	P _{max} kg	Gripple load class	G kg
GV				
TPZPEF8 31GV	1000	90	3	0,15
TPZPEF8 32GV	2000	90	3	0,19
TPZPEF8 33GV	3000	90	3	0,23
TPZPEF8 34GV	4000	90	3	0,27
TPZPEF8 35GV	5000	90	3	0,31
TPZPEF8 310GV	10000	90	3	0,47

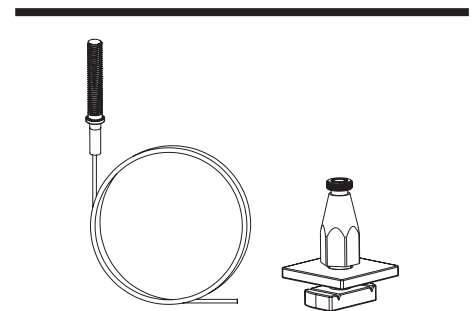

TPZPEF10 2 wire suspension with threaded end M10 and trapezium closure plus

article number	L mm	P _{max} kg	Gripple load class	G kg
GV				
TPZPEF10 21GV	1000	45	2	0,15
TPZPEF10 22GV	2000	45	2	0,17
TPZPEF10 23GV	3000	45	2	0,19
TPZPEF10 24GV	4000	45	2	0,20
TPZPEF10 25GV	5000	45	2	0,22
TPZPEF10 210GV	10000	45	2	0,31

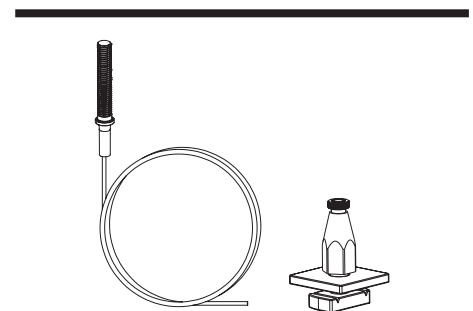

TPZPEF10 3 wire suspension with threaded end M10 and trapezium closure plus

article number	L mm	P _{max} kg	Gripple load class	G kg
GV				
TPZPEF10 31GV	1000	90	3	0,15
TPZPEF10 32GV	2000	90	3	0,19
TPZPEF10 33GV	3000	90	3	0,22
TPZPEF10 34GV	4000	90	3	0,26
TPZPEF10 35GV	5000	90	3	0,30
TPZPEF10 310GV	10000	90	3	0,47

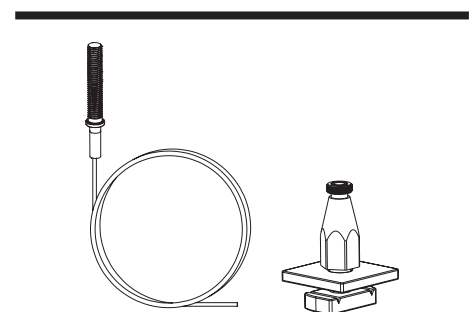

TPZPEF10 4 wire suspension with threaded end M10 and trapezium closure plus

article number	L mm	P _{max} kg	Gripple load class	G kg
GV				
TPZPEF10 41GV	1000	225	4	0,21
TPZPEF10 42GV	2000	225	4	0,30
TPZPEF10 43GV	3000	225	4	0,39
TPZPEF10 44GV	4000	225	4	0,48
TPZPEF10 45GV	5000	225	4	0,56
TPZPEF10 410GV	10000	225	4	0,99

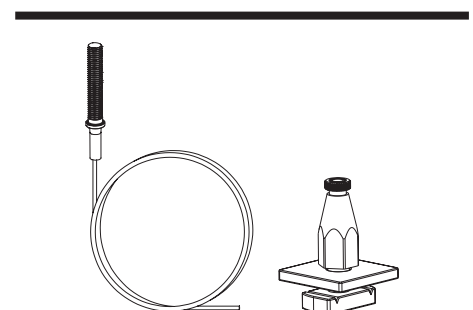

Fastenings

Suspension components

TPZPFR 2 wire suspension with loop and trapezium closure plus

article number	L mm	P _{max} kg	Gripple load class	G kg
GV				
TPZPFR 21GV	1000	45	2	0,13
TPZPFR 22GV	2000	45	2	0,14
TPZPFR 23GV	3000	45	2	0,16
TPZPFR 24GV	4000	45	2	0,17
TPZPFR 25GV	5000	45	2	0,19
TPZPFR 210GV	1000	45	2	0,29

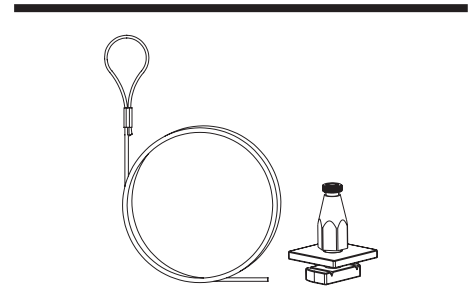

TPZPFR 3 wire suspension with loop and trapezium closure plus

article number	L mm	P _{max} kg	Gripple load class	G kg
GV				
TPZPFR 31GV	1000	90	3	0,13
TPZPFR 32GV	2000	90	3	0,17
TPZPFR 33GV	3000	90	3	0,21
TPZPFR 34GV	4000	90	3	0,23
TPZPFR 35GV	5000	90	3	0,27
TPZPFR 310GV	1000	90	3	0,44

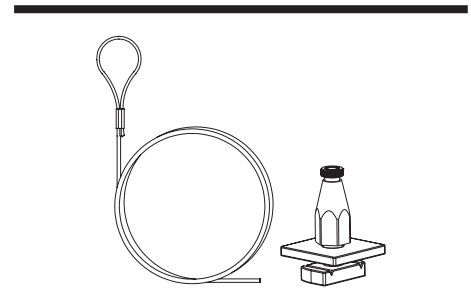

TPZPFR 4 wire suspension with loop and trapezium closure plus

article number	L mm	P _{max} kg	Gripple load class	G kg
GV				
TPZPFR 41GV	1000	225	4	0,22
TPZPFR 42GV	2000	225	4	0,29
TPZPFR 43GV	3000	225	4	0,39
TPZPFR 44GV	4000	225	4	0,45
TPZPFR 45GV	5000	225	4	0,62
TPZPFR 410GV	1000	225	4	1,09

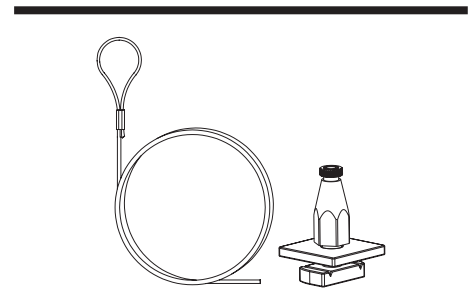

TPZPSP 2 wire suspension with cross anchor and trapezium closure plus

article number	L mm	P _{max} kg	Gripple load class	G kg
GV				
TPZPSP 21GV	1000	45	2	0,13
TPZPSP 22GV	2000	45	2	0,14
TPZPSP 23GV	3000	45	2	0,16
TPZPSP 24GV	4000	45	2	0,18
TPZPSP 25GV	5000	45	2	0,20
TPZPSP 210GV	10000	45	2	0,29

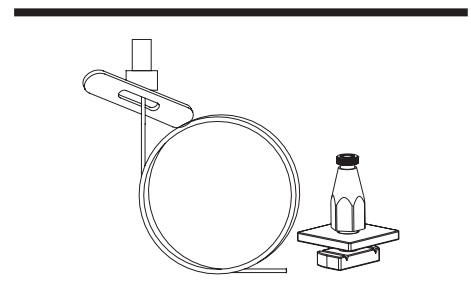

Fastenings

Suspension components

TPZPSP 3 wire suspension with cross anchor and trapezium closure plus

article number	L mm	P _{max} kg	Gripple load class	G kg
GV				
TPZPSP 31GV	1000	90	3	0,13
TPZPSP 32GV	2000	90	3	0,17
TPZPSP 33GV	3000	90	3	0,20
TPZPSP 34GV	4000	90	3	0,25
TPZPSP 35GV	5000	90	3	0,28
TPZPSP 310GV	10000	90	3	0,48

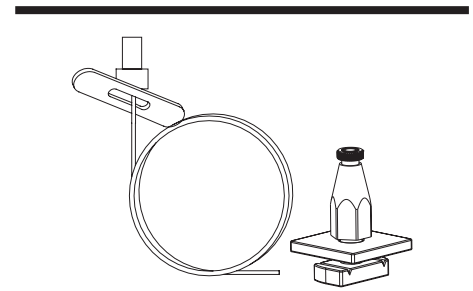

TPZPTH 2 wire suspension with trapezium sheet metal hook and trapezium closure plus

article number	L mm	P _{max} kg	Gripple load class	G kg
GV				
TPZPTH 21GV	1000	45	2	0,13
TPZPTH 22GV	2000	45	2	0,14
TPZPTH 23GV	3000	45	2	0,16
TPZPTH 24GV	4000	45	2	0,18
TPZPTH 25GV	5000	45	2	0,20
TPZPTH 210GV	10000	45	2	0,29

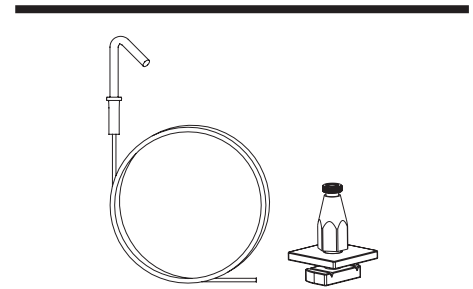

YAJEC 1 Y-Fit accessory with hook

article number	L mm	P _{max} kg	Gripple load class	G kg
GV				
YAJEC 1150GV	150	15	1	0,05
YAJEC 1300GV	300	15	1	0,05
YAJEC 1500GV	500	15	1	0,06
YAJEC 1800GV	800	15	1	0,08

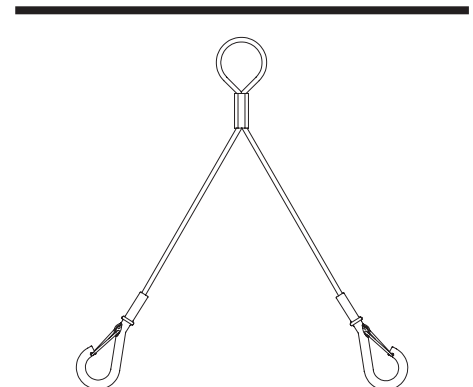

YAJEC 2 Y-Fit accessory with hook

article number	L mm	P _{max} kg	Gripple load class	G kg
GV				
YAJEC 2150GV	150	45	2	0,06
YAJEC 2300GV	300	45	2	0,07
YAJEC 2500GV	500	45	2	0,07
YAJEC 2800GV	800	45	2	0,08

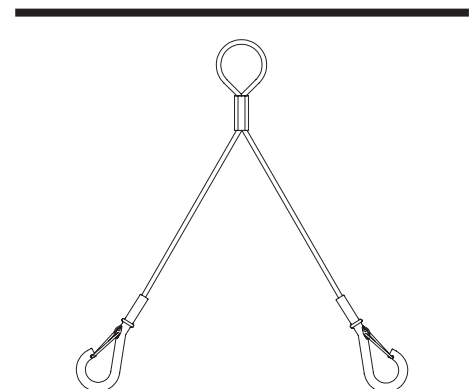

Fastenings

Suspension components

YAJEC 3 Y-Fit accessory with hook

article number	L mm	P _{max} kg	Gripple load class	G kg
GV				
YAJEC 3150GV	150	90	3	0,10
YAJEC 3300GV	300	90	3	0,13
YAJEC 3500GV	500	90	3	0,17
YAJEC 3800GV	800	90	3	0,26

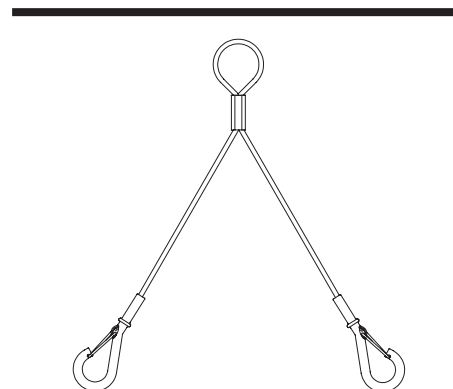

YAJCT 2 Y-Fit accessory with hook for cable trays

article number	L mm	P _{max} kg	Gripple load class	G kg
GV				
YAJCT 2150GV	150	45	2	0,06
YAJCT 2300GV	300	45	2	0,07

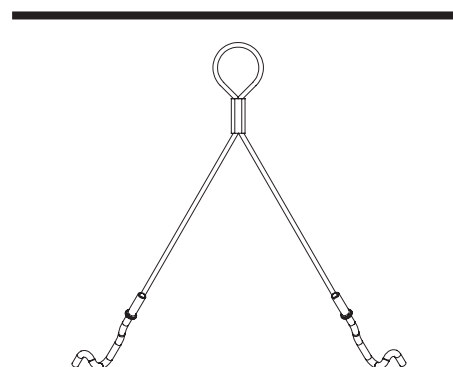

GRIPADAP thread adaptor with hole

article number	Ø mm	G kg
GV		
GRIPADAP 6GV	6	0,01
GRIPADAP 8GV	8	0,03

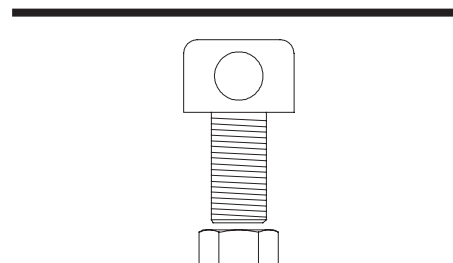

GRIPTRAP trapezium lock

Trapeze lock for arranging several levels on one cable.

article number	Gripple load class	G kg
GV		
GRIPTRAP 2GV	2	0,02
GRIPTRAP 3GV	3	0,03

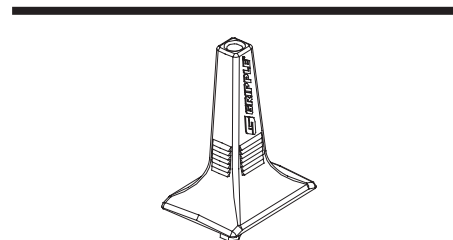

Fastenings

Suspension components

GRIPTRAPP trapezium lock plus

Trapeze lock for arranging several levels on one cable.

article number	Grip load class	G kg
GV		
GRIPTRAPP 2GV	2	0,10
GRIPTRAPP 3GV	3	0,14
GRIPTRAPP 4GV	4	0,17

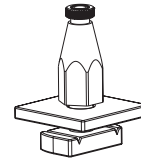

SPRINGCLIP spring clip

Push-in fastening for drills of 6 to 8 mm.

article number	G kg
GV	
SPRINGCLIP GV	0,01

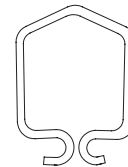

GCB beam clip

Impact clip, light design. Ideal in combination with hooks (EC).

article number	t mm	P _{max} kg	G kg
GV			
GCB 24GV	2 - 4	72	0,01
GCB 59GV	5 - 9	90	0,01
GCB 1016GV	10 - 16	90	0,02
GCB 1720GV	17 - 20	90	0,02

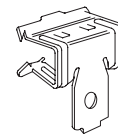

TIGERCLIP Tiger clip

Impact clip. Ideal in combination with hooks (EC).

article number	t mm	P _{max} kg	G kg
GV			
TIGERCLIP 28GV	2 - 8	120	0,01
TIGERCLIP 816GV	8 - 16	120	0,01

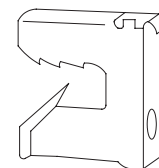

GRIPM pigtail anchor bolt

Rapid attachment of a loop in drill holes.

article number	Ø mm	L mm	G kg
GV			
GRIPM 620GV	6	20	0,03
GRIPM 645GV	6	45	0,03
GRIPM 845GV	8	45	0,08



Fastenings

Suspension components

GRIPWIS wire end cap

For secure and accurate attachment of wire cable end.

article number	Grippler load class	G kg
GV		
GRIPWIS GV	2 - 3	0,01



GRIPCLE 1 adjustment key

Replacement key for universal locks.

article number	Grippler load class	G kg
GV		
GRIPCLE 1	1 - 3	0,02

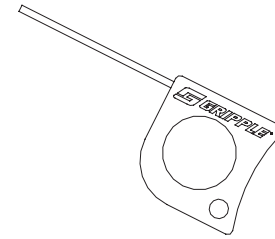

GRIPCLE 2 adjustment key

Replacement key for universal locks.

article number	Grippler load class	G kg
GV		
GRIPCLE 2	4 - 5	0,02

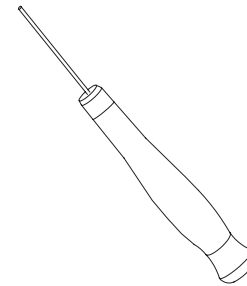

GRIPPINC wire cutter

Special tool for splice-free shortening of wire cable.

article number	Q_{Lk} kN/m	G kg
GV		
GRIPPINC	1 - 3	0,30
GRIPPINC 6	4 - 5	7,90



Fastenings

Bolting fasteners/bolts and nuts

KLR fixing set

For an application example, see the chapter assembly.

article number	G
	kg/100
GV	
KLR	0,9

accessories included:

- 2 x **FRSV 6x12** round-head screw with short square (page H34)
- 2 x **SEMS 6** hexagon nut, self-locking, DIN 6923 (page H41)

article number	G
	kg/100
E	
KLR E	0,9

accessories included:

- 2 x **FRSV 6x12E** round-head screw with short square (page H35)
- 2 x **SEMS 6E** hexagon nut, self-locking, DIN 6923 (page H41)

article number	G
	kg/100
GV	
KLR 6x25	1,4

accessories included:

- 2 x **FRS 6x25** round-head screw with square, DIN 603 (page H35)
- 2 x **SEMS 6** hexagon nut, self-locking, DIN 6923 (page H41)

article number	G
	kg/100
E	
KLR 6x25E	1,4

accessories included:

- 2 x **FRS 6x25E** round-head screw with square, DIN 603 (page H35)
- 2 x **SEMS 6E** hexagon nut, self-locking, DIN 6923 (page H41)

accessories optional:

- FRSV** round-head screw with short square (page H34)
- FRS** round-head screw with square, DIN 603 (page H35)
- SEMS** hexagon nut, self-locking, DIN 6923 (page H41)

KLS fixing set

For an application example, see the chapter assembly.

article number	Ø	L	G
	mm	mm	kg/100
GV			
KLS 8x16	8	16	1,8

accessories included:

- 1 x **FRSV 8x16** round-head screw with short square (page H34)
- 1 x **SEMS 8** hexagon nut, self-locking, DIN 6923 (page H41)

article number	Ø	L	G
	mm	mm	kg/100
GV			
KLS 8x25	8	25	2,2

accessories included:

- 1 x **FRS 8x25** round-head screw with square, DIN 603 (page H35)
- 1 x **SEMS 8** hexagon nut, self-locking, DIN 6923 (page H41)

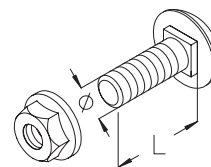
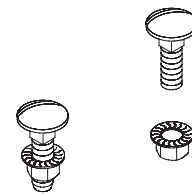

Fastenings

Bolting fasteners/bolts and nuts

KLS fixing set

For an application example, see the chapter assembly.

article number	Ø mm	L mm	G kg/100
GV			
KLS 10x20	10	20	3,9

accessories included:

- 1 x **FRSV 10x20** round-head screw with short square (page H34)
- 1 x **SEMS 10** hexagon nut, self-locking, DIN 6923 (page H41)

article number	Ø mm	L mm	G kg/100
F			
KLS 10x20F	10	20	4

accessories included:

- 1 x **FRSV 10x20F** round-head screw with short square (page H34)
- 1 x **SEM 10F** hexagon-nut, DIN 934 (page H41)
- 1 x **US 10x21F** square washer, DIN 125 (page H39)

article number	Ø mm	L mm	G kg/100
E			
KLS 8x16E	8	16	1,8

accessories included:

- 1 x **FRSV 8x16E** round-head screw with short square (page H35)
- 1 x **SEMS 8E** hexagon nut, self-locking, DIN 6923 (page H41)

article number	Ø mm	L mm	G kg/100
E			
KLS 8x25E	8	25	2,2

accessories included:

- 1 x **FRS 8x25E** round-head screw with square, DIN 603 (page H35)
- 1 x **SEMS 8E** hexagon nut, self-locking, DIN 6923 (page H41)

article number	Ø mm	L mm	G kg/100
E			
KLS 10x20E	10	20	3,9

accessories included:

- 1 x **FRSV 10x20E** round-head screw with short square (page H35)
- 1 x **SEM 10E** hexagon-nut, DIN 934 (page H41)
- 1 x **US 10x21E** square washer, DIN 125 (page H40)

FRSV round-head screw with short square

article number	Ø mm	D mm	d mm	L mm	G kg/100
GV					
FRSV 6x12	6	16	1,5	12	0,5
FRSV 6x16	6	16	1,5	16	0,7
FRSV 8x16	8	20	2,0	16	1,3
FRSV 10x20	10	24	2,5	20	2,3
F					
FRSV 10x20F	10	24	2,5	20	2,3

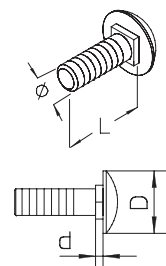
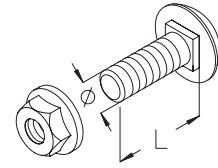

Fastenings

Bolting fasteners/bolts and nuts

FRSV round-head screw with short square

article number	Ø mm	D mm	d mm	L mm	G kg/100
E					
FRSV 6x12E	6	16	1,5	12	0,5
FRSV 6x16E	6	16	1,5	16	0,7
FRSV 8x16E	8	20	2,0	16	1,3
FRSV 10x20E	10	24	2,5	20	2,3
E4					
FRSV 6x12E4	6	16	1,5	12	0,5
FRSV 10x20E4	10	24	2,5	20	2,4

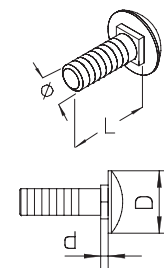

FRS round-head screw with square, DIN 603

article number	Ø mm	D mm	d mm	L mm	G kg/100
GV					
FRS 6x25	6	16	4	25	0,9
FRS 8x20	8	20	5	20	1,4
FRS 8x25	8	20	5	25	1,5
FRS 8x35	8	20	5	35	1,9
FRS 8x50	8	20	5	50	2,5
FRS 10x30	10	24	6	30	2,8
FRS 12x30	12	30	8	30	4,6
F					
FRS 10x30F	10	24	6	30	2,8
FRS 12x30F	12	30	8	30	4,6
E					
FRS 6x16E	6	16	4	16	0,7
FRS 6x20E	6	16	4	20	0,8
FRS 6x25E	6	16	4	25	0,9
FRS 8x20E	8	20	5	20	1,4
FRS 8x25E	8	20	5	25	1,5
FRS 8x35E	8	20	5	35	1,9
FRS 8x50E	8	20	5	50	2,5
FRS 10x30E	10	24	6	30	2,8
FRS 12x30E	12	30	8	30	4,6

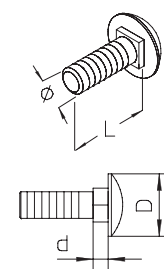

FKS slotted cylinder head screw, DIN 84

article number	Ø mm	D mm	L mm	t mm	G kg/100
GV					
FKS 6x10	6	12	10	4	0,4
FKS 6x20	6	12	20	4	0,6
FKS 6x25	6	12	25	4	0,7
FKS 8x20	8	16	20	5	1,3
E					
FKS 6x10E	6	12	10	4	0,4
FKS 6x16E	6	12	16	4	0,4
FKS 6x20E	6	12	20	4	0,6
FKS 6x25E	6	12	25	4	0,7

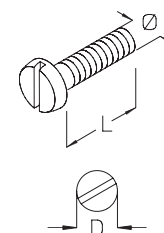

Fastenings

Bolting fasteners/bolts and nuts

FKS slotted cylinder head screw, DIN 84

article number	Ø mm	D mm	L mm	t mm	G kg/100
E4					
FKS 6x16E4	6	12	16	4	0,4

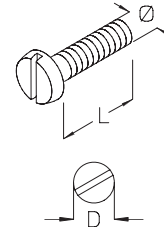

KLRL clamping assembly

article number	G kg/100
S	
KLRL	1

accessories included:

- 2 x **FRSV 6x16** round-head screw with short square (page H34)
- 2 x **SEMS 6** hexagon nut, self-locking, DIN 6923 (page H41)

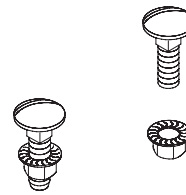

article number	G kg/100
E	
KLRL E	1

accessories included:

- 2 x **FRSV 6x16E** round-head screw with short square (page H35)
- 2 x **SEMS 6E** hexagon nut, self-locking, DIN 6923 (page H41)

IK hexagon socket head screw, DIN 912

article number	Ø mm	D mm	L mm	IK mm	G kg/100
GV					
IK 6x20	6	10,2	20	5	0,7
IK 8x20	8	13,3	20	6	1,3
IK 8x25	8	13,3	25	6	1,5
IK 8x30	8	13,3	30	6	1,7
IK 8x40	8	13,3	40	6	2,1
IK 10x20	10	16,3	20	8	2,3
IK 10x25	10	16,3	25	8	2,5
IK 10x30	10	16,3	30	8	2,8
IK 10x40	10	16,3	40	8	3,3
IK 12x20	12	18,3	20	10	3,2
IK 12x25	12	18,3	25	10	3,6
IK 12x30	12	18,3	30	10	3,9
IK 12x40	12	18,3	40	10	4,7
IK 12x50	12	18,3	50	10	5,5

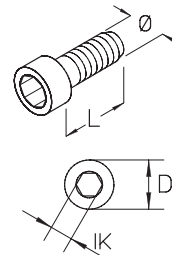

Fastenings

Bolting fasteners/bolts and nuts

IK hexagon socket head screw, DIN 912

article number	Ø mm	D mm	L mm	IK mm	G kg/100
E					
IK 8x10E	8	13,3	10	6	1,0
IK 8x20E	8	13,3	20	6	1,3
IK 8x25E	8	13,3	25	6	1,3
IK 8x30E	8	13,3	30	6	1,7
IK 8x40E	8	13,3	40	6	2,1
IK 8x50E	8	13,3	50	6	2,5
IK 10x20E	10	16,3	20	8	2,3
IK 10x25E	10	16,3	25	8	2,5
IK 10x30E	10	16,3	30	8	2,8
IK 10x40E	10	16,3	40	8	3,3
IK 12x20E	12	18,3	20	10	3,2
IK 12x25E	12	18,3	25	10	3,6
IK 12x30E	12	18,3	30	10	3,9
IK 12x40E	12	18,3	40	10	4,7
IK 12x50E	12	18,3	50	10	5,5

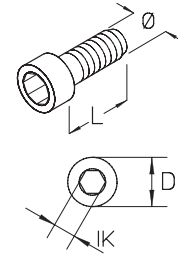

SES hexagon head bolt, DIN 933

article number	Ø mm	L mm	SW mm	G kg/100
GV				
SES 6x16	6	16	10	0,5
SES 6x20	6	20	10	0,6
SES 6x25	6	25	10	0,7
SES 6x30	6	30	10	0,8
SES 8x16	8	16	13	1,1
SES 8x20	8	20	13	1,2
SES 8x25	8	25	13	1,4
SES 8x30	8	30	13	1,4
SES 8x40	8	40	13	1,9
SES 8x110	8	110	13	4,1
SES 10x20	10	20	17(16)	2,1
SES 10x25	10	25	17(16)	2,4
SES 10x30	10	30	17(16)	2,6
SES 10x40	10	40	17(16)	3,1
SES 10x75	10	75	17(16)	4,7
SES 10x90	10	90	17(16)	5,6
SES 10x100	10	100	17(16)	6,1
SES 12x20	12	20	19(18)	3,1
SES 12x25	12	25	19(18)	3,4
SES 12x30	12	30	19(18)	3,8
SES 12x40	12	40	19(18)	4,5
SES 12x50	12	50	19(18)	5,2

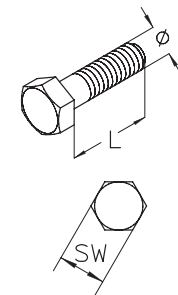

Fastenings

Bolting fasteners/bolts and nuts

SES hexagon head bolt, DIN 933

article number	Ø mm	L mm	SW mm	G kg/100
F				
SES 10x20F	10	20	17(16)	2,1
SES 10x25F	10	25	17(16)	2,4
SES 10x30F	10	30	17(16)	2,6
SES 10x55F	10	55	17(16)	3,9
SES 10x75F	10	75	17(16)	4,9
SES 10x90F	10	90	17(16)	5,6
SES 10x100F	10	100	17(16)	6,1
SES 12x20F	12	20	19(18)	3,1
SES 12x30F	12	30	19(18)	3,8
SES 12x40F	12	40	19(18)	4,5
SES 12x50F	12	50	19(18)	5,2
SES 12x70F	12	70	19(18)	6,6

E				
SES 6x16E	6	16	10	0,5
SES 8x16E	8	16	13	1,1
SES 6x20E	6	20	10	0,6
SES 8x20E	8	20	13	1,2
SES 8x25E	8	25	13	1,4
SES 8x30E	8	30	13	1,5
SES 10x20E	10	20	17	2,1
SES 10x30E	10	30	17	2,6
SES 10x75E	10	75	17(16)	4,9
SES 10x100E	10	100	17(16)	6,1

E4				
SES 8x20E4	8	20	13	1,2
SES 8x30E4	8	30	13	1,5
SES 10x20E4	10	20	17	2,1
SES 10x75E4	10	75	17(16)	4,9
SES 10x100E4	10	100	17(16)	6,1

SEH hexagon wood screw

article number	Ø mm	L mm	SW mm	G kg/100
GV				
SEH 8x50	8	50	13	1,8
SEH 8x60	8	60	13	2,1
SEH 10x50	10	50	17	3,2
SEH 10x60	10	60	17	3,6
SEH 10x80	10	80	17	4,5

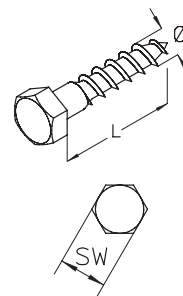
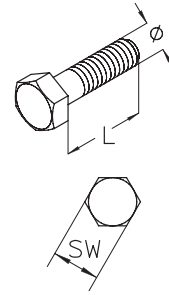

Fastenings

Bolting fasteners/bolts and nuts

FR spring ring

article number	Ø mm	D mm	G kg/100
GV			
FR B6	6,1	11,8	0,10
FR B8	8,1	14,8	0,15
FR B10	10,2	18,1	0,20
FR B12	12,2	21,1	0,25
E			
FR B6E	6,1	11,8	0,10
FR B8E	8,1	14,8	0,15
FR B10E	10,2	18,1	0,20
FR B12E	12,2	21,1	0,25
E4			
FR B6E4	6,1	11,8	0,10
FR B8E4	8,1	14,8	0,15
FR B10E4	10,2	18,1	0,20
FR B12E4	12,2	21,1	0,25



FS serrated lock washer

article number	Ø mm	D mm	G kg/100
GV			
FS 6	6,4	11,0	0,04
FS 8	8,2	14,0	0,08
FS 10	10,5	18,0	0,13
FS 12	12,5	20,5	0,17
E			
FS 6E	6,4	11,0	0,04
FS 8E	8,2	14,0	0,08
FS 10E	10,5	18,0	0,13
FS 12E	12,5	20,5	0,17



US 125 square washer, DIN 125

article number	Ø mm	D mm	t mm	G kg/100
GV				
US 6x12	6,4	12,5	1,6	0,1
US 8x17	8,4	17,0	2,0	0,2
US 10x21	10,5	21,0	2,0	0,4
US 13x24	13,0	24,0	2,5	0,6
US 17x30	17,0	30,0	3,0	1,1
F				
US 10x21F	10,5	21,0	2,0	0,4
US 13x24F	13,0	24,0	2,5	0,6
US 17x30F	17,0	30,0	3,0	1,1

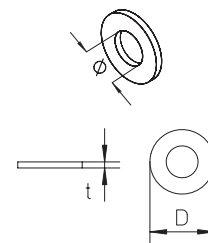

Fastenings

Bolting fasteners/bolts and nuts

US 125 square washer, DIN 125

article number	Ø mm	D mm	t mm	G kg/100
E				
US 6x12E	6,4	12,5	1,5	0,1
US 8x17E	8,4	17,0	1,5	0,2
US 10x21E	10,5	21,0	0,0	0,4
US 13x24E	13,0	24,0	2,5	1,2
E4				
US 6x12E4	6,4	12,5	1,5	0,1
US 10x21E4	10,5	21,0	0,0	0,2
US 8x17E4	8,4	17,0	1,5	0,2

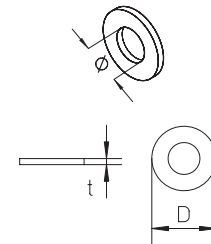

US 9021 square washer, DIN 9021

article number	Ø mm	D mm	t mm	G kg/100
GV				
US 6x18	6,4	18	1,6	0,3
US 8x25	8,4	25	2,0	0,7
US 10x30	10,5	30	2,5	1,2
US 13x40	13,0	40	3,0	2,7
F				
US 10x30F	10,5	30	2,5	1,2
US 13x40F	13,0	40	3,0	2,7
E				
US 6x18E	6,4	18	1,6	0,3
US 8x25E	8,4	25	2,0	0,7
US 10x30E	10,5	30	2,5	1,2
E4				
US 10x30E4	10,5	30	2,5	1,2

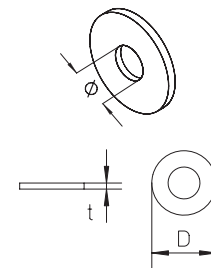

UVS captive washer

article number	Ø mm	D mm	t mm	G kg/100
PE				
UVS M6	6,0	12,5	1,30	< 0,01
UVS M8	8,0	16,2	1,65	< 0,01
UVS M10	10,5	30,0	2,10	< 0,01
UVS M10x24	10,0	24,0	2,10	< 0,01

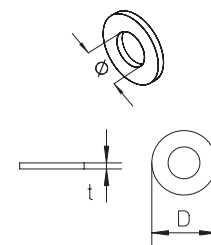

Fastenings

Bolting fasteners/bolts and nuts

SEMS hexagon nut, self-locking, DIN 6923

article number	Ø mm	D mm	t mm	SW mm	G kg/100
GV					
SEMS 6	6	14	5,5	10	0,3
SEMS 8	8	17	7,5	13	0,7
SEMS 10	10	21	9,5	15	1,6
E					
SEMS 6E	6	14	5,5	10	0,3
SEMS 8E	8	17	7,5	13	0,7
SEMS 10E	10	21	9,5	15	1,6

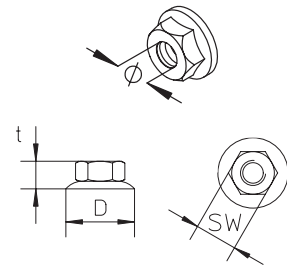

SEM hexagon-nut, DIN 934

article number	Ø mm	t mm	SW mm	G kg/100
GV				
SEM 6	6	5,0	10	0,3
SEM 8	8	6,5	13	0,5
SEM 10	10	8,0	17(15)	1,2
SEM 12	12	10,0	19(18)	1,7
F				
SEM 10F	10	8,0	17(15)	1,2
SEM 12F	12	10,0	19(18)	1,7
E				
SEM 6E	6	5,0	10	0,3
SEM 8E	8	6,5	13	0,5
SEM 10E	10	8,0	17(15)	1,2
SEM 12E	12	10,0	19(18)	1,7
E4				
SEM 6E4	6	5,0	10	0,3
SEM 8E4	8	6,5	13	0,5
SEM 10E4	10	8,0	17(15)	1,2

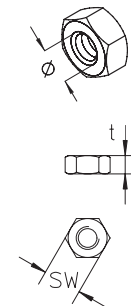

RUS 41 stabilization plate, KHA profiles

For an application example, see the chapter assembly.

article number	H mm	B mm	Ø mm	t mm	G kg/100
F					
RUS 41-L13F	40	46	13	2,5	4,00
E					
RUS 41-L13E	40	46	13	1,8	2,84

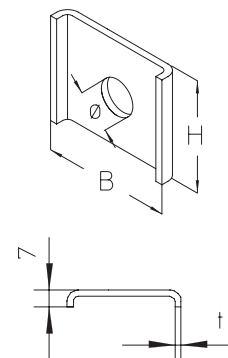

Fastenings

Bolting fasteners/bolts and nuts

RUS 50 mounting plate, KHA profiles

article number	H mm	B mm	Ø mm	t mm	G kg/100
F					
RUS 50-L13F	50	50	13	4	7,54
E					
RUS 50-L13E	50	50	13	4	7,54

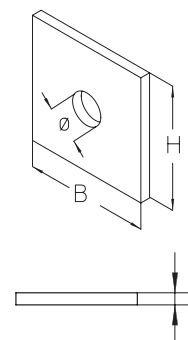

SSK protection end cap

article number	IK mm	G kg/100
SSK 6		
SSK 6	10	0,1
SSK 8	13	0,1
SSK 10	17	0,2



SEMSS hexagon-nut, self-locking, DIN 985

article number	Ø mm	t mm	SW mm	G kg/100
GV				
SEMSS 6	6	6	10	0,2
SEMSS 10	10	10	17	1,1
E				
SEMSS 6E	6	6	10	0,2
SEMSS 10E	10	10	17	1,1

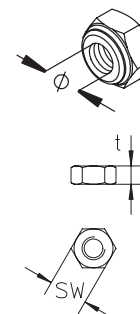

Fastenings

Channel nuts and bolts

AM22 channel nut, A41/ KHA 41/ KHAL 41

For an application example, see the chapter assembly.

article number	Ø mm	t mm	G kg/100
GV			
AM22 M6	6	6,0	2,6
AM22 M8	8	6,0	2,4
AM22 M10	10	8,0	3,3
AM22 M12	12	9,5	4,2

F			
AM22 M6F	6	6,0	2,8
AM22 M8F	8	6,0	2,6
AM22 M10F	10	8,0	3,5
AM22 M12F	12	9,0	4,2

E4			
AM22 M6E4	6	6,0	2,6
AM22 M8E4	8	6,0	2,4
AM22 M10E4	10	8,0	3,3
AM22 M12E4	12	9,5	4,2

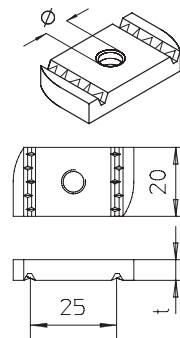

AMF22 channel spring nut, A41

For an application example, see the chapter assembly.

article number	Ø mm	t mm	G kg/100
GV			
AMF22 M6	6	6,0	2,8
AMF22 M8	8	6,0	2,6
AMF22 M10	10	8,0	3,5
AMF22 M12	12	9,5	4,4

F			
AMF22 M6F	6	6,0	3,0
AMF22 M8F	8	6,0	2,8
AMF22 M10F	10	8,0	3,7
AMF22 M12F	12	9,5	4,7

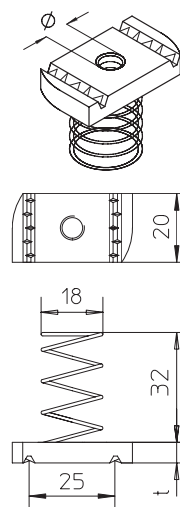

HS22 tee-head bolt, A2/ A4

For an application example, see the chapter assembly.

article number	Ø mm	L mm	G kg/100
GV			
HS22 12x30	12	30	9,5
HS22 12x40	12	40	10,0
HS22 12x50	12	50	10,8
HS22 12x60	12	60	11,4
HS22 16x40	16	40	16,2
HS22 16x60	16	60	18,6

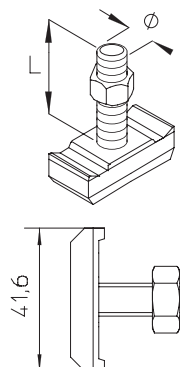

Fastenings

Channel nuts and bolts

HS22 tee-head bolt, A2/ A4

For an application example, see the chapter assembly.

article number	Ø mm	L mm	G kg/100
F			
HS22 10x80F	10	80	9,7
E4			
HS22 10x80E4	10	80	9,7
HS22 12x30E4	12	30	9,6
HS22 12x40E4	12	40	10,1
HS22 12x50E4	12	50	10,9
HS22 12x60E4	12	60	11,5
HS22 16x40E4	16	40	16,3
HS22 16x60E4	16	60	18,7

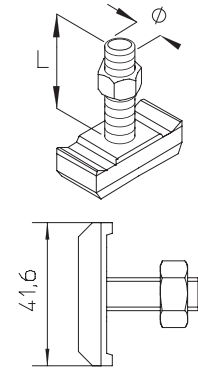

AM18 channel nut, A7/ A8

For an application example, see the chapter assembly.

article number	Ø mm	t mm	G kg/100
GV			
AM18 M6	6	6,0	2,6
AM18 M8	8	6,0	2,4
AM18 M10	10	8,0	3,3
AM18 M12	12	9,5	4,2
F			
AM18 M6F	6	6,0	2,8
AM18 M8F	8	6,0	2,6
AM18 M10F	10	8,0	3,5
AM18 M12F	12	9,5	4,5
E4			
AM18 M6E4	6	6,0	3,0
AM18 M8E4	8	6,0	2,9
AM18 M10E4	10	8,0	3,6
AM18 M12E4	12	9,5	3,4

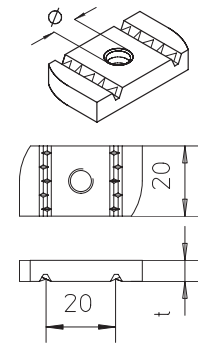

AMA18 channel nut, A7/ A8

For an application example, see the chapter assembly.

article number	Ø mm	t mm	G kg/100
F			
AMA18 M6F	6	5,0	2,7
AMA18 M8F	8	6,0	3,0
AMA18 M10F	10	8,0	3,8
E			
AMA18 M6E	6	6,0	2,7
AMA18 M8E	8	6,0	3,0
AMA18 M10E	10	8,0	3,8

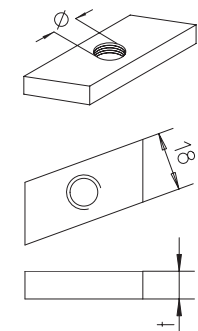

Fastenings

Channel nuts and bolts

AMF18 channel spring nut, A7/ A8

For an application example, see the chapter assembly.

article number	Ø mm	t mm	G kg/100
GV			
AMF18 M6	6	6,0	2,7
AMF18 M8	8	6,0	2,5
AMF18 M10	10	8,0	3,4
AMF18 M12	12	9,5	4,3
F			
AMF18 M6F	6	6,0	2,9
AMF18 M8F	8	6,0	2,7
AMF18 M10F	10	8,0	3,6
AMF18 M12F	12	9,5	4,6

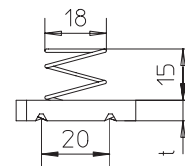
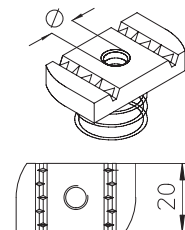

HS18 tee-head bolt, A7/ A8/ A9

For an application example, see the chapter assembly.

article number	Ø mm	L mm	G kg/100
GV			
HS18 10x30	10	30	5,9
HS18 10x40	10	40	6,3
HS18 10x50	10	50	6,9
HS18 10x60	10	60	7,4
HS18 12x30	12	30	7,4
HS18 12x40	12	40	7,9
HS18 12x60	12	60	9,4
HS18 16x40	16	40	13,4
HS18 16x60	16	60	16,0
HS18 16x80	16	80	18,8
E4			
HS18 10x30E4	10	30	6,0
HS18 10x40E4	10	40	6,5
HS18 10x50E4	10	50	7,0

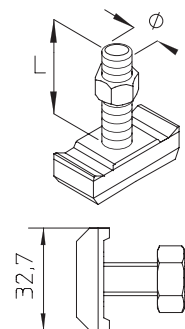

AM16 channel nut, B7

For an application example, see the chapter assembly.

article number	Ø mm	t mm	G kg/100
F			
AM16 M6F	6	5,0	1
AM16 M8F	8	5,0	1
E4			
AM16 M6E4	6	5,0	1

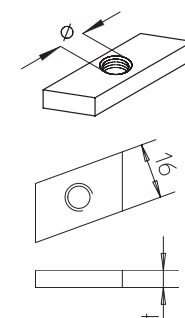

Fastenings

Channel nuts and bolts

HS16 Tee-head bolt

article number	Ø mm	L mm	G kg/100
GV			
HS16 8x20	8	20	3,0
HS16 8x40	8	40	3,9
HS16 10x30	10	30	4,6
HS16 10x50	10	50	5,8

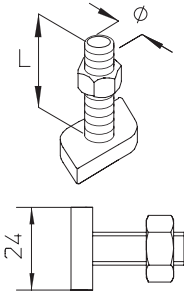

AM12 channel nut, B3/ B6

For an application example, see the chapter assembly.

article number	Ø mm	t mm	G kg/100
F			
AM12 M6F	6	5,0	1,0
AM12 M8F	8	5,0	0,9
E			
AM12 M8E	8	5,0	0,9

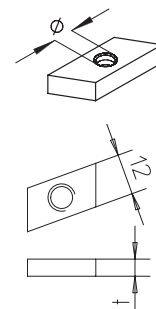

HS12 Tee-head bolt

article number	Ø mm	L mm	G kg/100
GV			
HS12 6x30	6	30	1,6
HS12 6x40	6	40	1,7
HS12 8x20	8	20	2,0
HS12 8x30	8	30	2,3
HS12 8x40	8	40	2,6
HS12 10x20	10	20	3,0
HS12 10x30	10	30	3,5
HS12 10x40	10	40	3,9
E4			
HS12 10x20E4	10	20	3,1
HS12 10x30E4	10	30	3,6
HS12 10x40E4	10	40	4,0

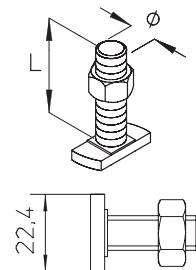

Fastenings

Channel nuts and bolts

AKB channel bolt, A7/ A8/ A9

For an application example, see the chapter assembly.

article number	Ø mm	L mm	G kg/100
AKB 6x25	6	25	2,4
AKB 8x25	8	25	3,5
AKB 8x35	8	35	3,7
AKB 8x45	8	45	4,0
AKB 10x35	10	35	5,4
AKB 10x45	10	45	5,9
AKB 12x35	12	35	7,0
AKB 12x45	12	45	7,7

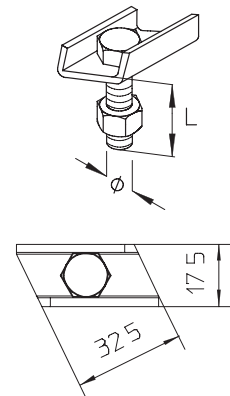

Fastenings

Electrical fastenings

SH QS multiple cable holder, metal

Multiple cable holder approved for continuous function E30 - E90, for wall and ceiling mounting. Please see the General Building Inspection Test Certificate (P-MPA-E-15-012) for further information.
The information on the number of cables relating to the use of NYM cable (3 x 1.5 mm²).

article number	number of cables	G kg/100
S		
SH 15Q S	15	3,08
SH 30Q S	30	7,20

accessories optional:

SD-BS straddling dowel, fire protection (page H51)

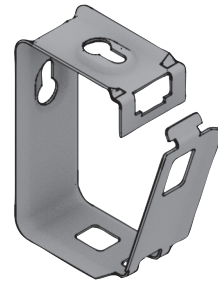

SH K multiple cable holder, plastic

flame-resistant according to specification of UL94 V-0 and fire hazard testing VDE 0471/DIN IEC 695 part 2-1, testing temperature T_{max}
The information on the number of cables relating to the use of NYM cable (3 x 1.5 mm²).

article number	number of cables	T _{max} °C	colour	G kg/100
PA				
SH 15 K	15	750	RAL 7035	2,88
SH 30 K	30	750	RAL 7035	4,90
SH 15 FWK	15	960	RAL 7030	2,95
SH 30 FWK	30	960	RAL 7030	5,02

accessories optional:

KOT K coupling piece, plastic (page H50)
BFS K quick-mounting clip for all-rounder cable holder, plastic (page H50)
BFS ND K quick-mounting clip for all-rounder cable holder, plastic with nail plug (page H50)
SN screw nail anchor (page H51)
KSD plastic plug-in dowel (page H51)

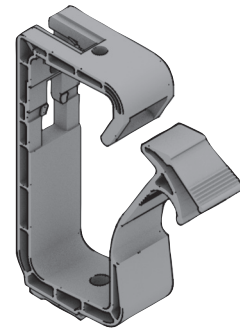

SH ND K multiple cable holder, plastic with nail plug

flame-resistant according to specification of UL94 V-0 and fire hazard testing VDE 0471/DIN IEC 695 part 2-1, testing temperature T_{max}
The information on the number of cables relating to the use of NYM cable (3 x 1.5 mm²).

article number	number of cables	T _{max} °C	colour	G kg/100
PA				
SH 15 ND K	15	750	RAL 7035	3,48
SH 30 ND K	30	750	RAL 7035	5,56

accessories included:

1 x **BFS ND K** quick-mounting clip for all-rounder cable holder, plastic with nail plug (page H50)

article number	number of cables	T _{max} °C	colour	G kg/100
PA				
SH 15 ND FWK	15	960	RAL 7030	3,88
SH 30 ND FWK	30	960	RAL 7030	6,02

accessories included:

1 x **BFS ND FWK** quick-mounting clip for all-rounder cable holder, plastic with nail plug (page H50)

accessories optional:

KOT K coupling piece, plastic (page G50)

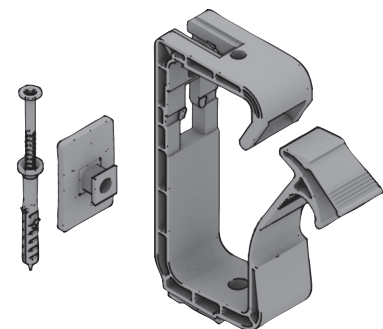

Fastenings

Electrical fastenings

SHK K cable holder, plastic

flame-resistant according to fire hazard testing VDE 0471/DIN IEC 695 part 2-1, testing temperature T_{max}
 Suitable for applications with limited installation height. The information on the number of cables relating to the use of NYM cable (3 x 1.5 mm²).

article number	H mm	number of cables	T_{max} °C	colour	G kg/100
PA					
SHK 10 K	58	10	750	RAL 7035	2,27
SHK 20 K	58	20	750	RAL 7035	2,70
SHK 40 K	58	40	750	RAL 7035	4,86

accessories optional:

SN screw nail anchor (page H51)
KSD plastic plug-in dowel (page H51)

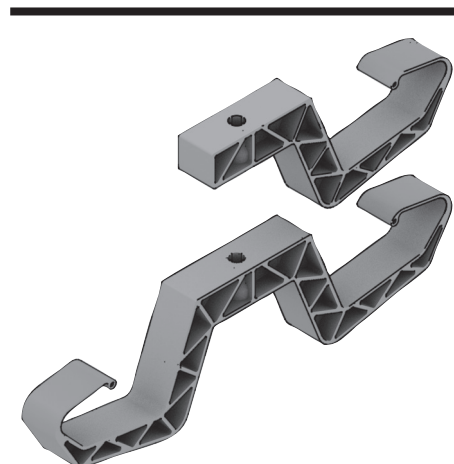

SHK ND K cable holder, plastic with nail plug

flame-resistant according to fire hazard testing VDE 0471/DIN IEC 695 part 2-1, testing temperature T_{max}
 Suitable for applications with limited installation height. The information on the number of cables relating to the use of NYM cable (3 x 1.5 mm²).

article number	H mm	number of cables	T_{max} °C	colour	G kg/100
PA					
SHK 10 ND K	58	10	750	RAL 7035	3,16
SHK 20 ND K	58	20	750	RAL 7035	3,64
SHK 40 ND K	58	40	750	RAL 7035	5,40

accessories included:

1 x **SN 6x50** screw nail anchor (page H51)

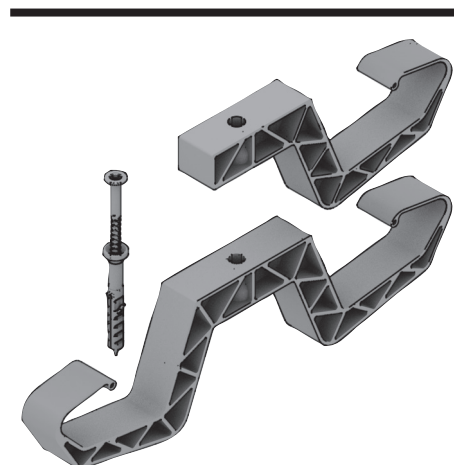

LK K cable holder, plastic

flame-resistant according to specification of UL94 V-0 and fire hazard testing VDE 0471/DIN IEC 695 part 2-1, testing temperature T_{max}
 Suitable for applications with low installation height. The information on the number of cables relating to the use of NYM cable (3 x 1.5 mm²).

article number	H mm	number of cables	T_{max} °C	colour	G kg/100
PA					
LK 8 K	16	8	750	RAL 7035	1,23
LK 10 K	16	10	750	RAL 7035	1,11
LK 16 K	16	16	750	RAL 7035	1,73
LK 8 FWK	16	8	960	RAL 7030	1,10
LK 10 FWK	16	10	960	RAL 7030	0,89
LK 16 FWK	16	16	960	RAL 7030	1,60

accessories optional:

SN screw nail anchor (page H51)
KSD plastic plug-in dowel (page H51)

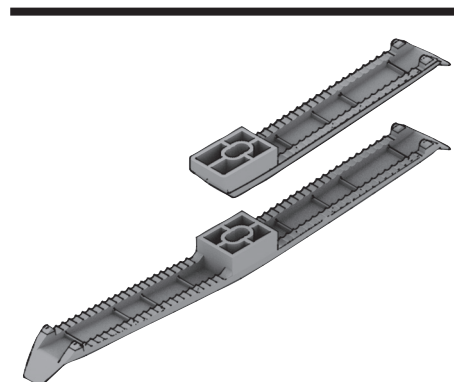

Fastenings

Electrical fastenings

LK ND K cable holder, plastic with moulded-in nail plug

flame-resistant according to specification of UL94 V-0 and fire hazard testing VDE 0471/DIN IEC 695 part 2-1, testing temperature T_{max}
 Suitable for applications with low installation height. The information on the number of cables relating to the use of NYM cable (3 x 1.5 mm²).

article number	H mm	number of cables	T_{max} °C	colour	G kg/100
PA					
LK 8 ND K	16	8	750	RAL 7035	1,92
LK 10 ND K	16	10	750	RAL 7035	1,68
LK 16 ND K	16	16	750	RAL 7035	2,63
LK 8 ND FWK	16	8	960	RAL 7030	2,24
LK 10 ND FWK	16	10	960	RAL 7030	1,80
LK 16 ND FWK	16	16	960	RAL 7030	2,68

accessories included:

1 x **SN 6x50** screwnail anchor (page H51)

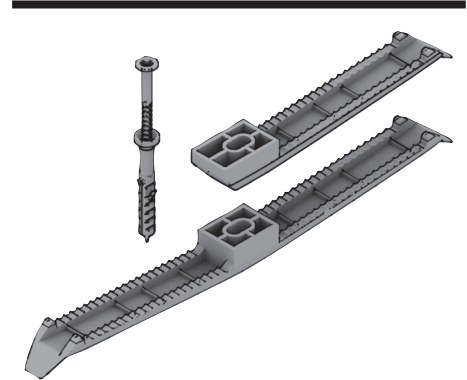

KOT K coupling piece, plastic

flame-resistant according to specification of UL94 V-0 and fire hazard testing VDE 0471/DIN IEC 695 part 2-1, testing temperature T_{max}

article number	T_{max} °C	colour	G kg/100
PA			
KOT K	750	RAL 7035	0,36
KOT FWK	960	RAL 7030	0,41



BFS K quick-mounting clip for all-rounder cable holder, plastic

flame-resistant according to specification of UL94 V-0 and fire hazard testing VDE 0471/DIN IEC 695 part 2-1, testing temperature T_{max}

article number	T_{max} °C	colour	G kg/100
PA			
BFS K	750	RAL 7035	0,41
BFS FWK	960	RAL 7030	0,43

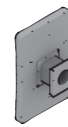

BFS ND K quick-mounting clip for all-rounder cable holder, plastic with nail plug

flame-resistant according to specification of UL94 V-0 and fire hazard testing VDE 0471/DIN IEC 695 part 2-1, testing temperature T_{max}

article number	T_{max} °C	colour	G kg/100
PA			
BFS ND K	750	RAL 7035	0,91
BFS ND FWK	960	RAL 7030	0,89

accessories included:

1 x **SN 6x50** screwnail anchor (page H51)

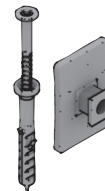

Fastenings

Electrical fastenings

SN screwnail anchor

article number	G
	kg
SN 6x50	0,01



KSD plastic plug-in dowel

article number	G
	kg
KSD 6x40	0,01



SD-BS straddling dowel, fire protection

manufacturer's information has to be observed strictly.

article number	Ø	D	t	L _{min}	G
	mm	mm	mm	mm	kg/100
GV					
SD-BS 6/5	6	6	0 - 5	46	0,3

